



County of Dare

P.O. Box 1000 | Manteo, NC 27954

DARE COUNTY BOARD OF COMMISSIONERS

Dare County Administration Building
954 Marshall C. Collins Dr., Manteo, NC

Monday, February 04, 2019

“HOW WILL THESE DECISIONS IMPACT OUR CHILDREN AND FAMILIES?”

AGENDA

9:00 AM CONVENE, PRAYER, PLEDGE OF ALLEGIANCE

ITEM 1 Opening Remarks - Chairman's Update

ITEM 2 Presentation of County Service Pins

ITEM 3 Employee of the Month

ITEM 4 Public Comments

ITEM 5 Report from the National Park Service

ITEM 6 Resolution Supporting Juvenile Crime Prevention Council Allocation Expansion

ITEM 7 Dare County N.C. Cooperative Extension Report to the People

ITEM 8 OT Enterprises - Conditional Use Permit Application for Cluster Home Development

ITEM 9 Kendrick Albaugh - Avon Zoning Map Amendment

ITEM 10 Update on the Bonner Bridge Replacement

ITEM 11 Series 2019 Limited Obligation Bonds Reimbursement Resolution & Capital Project Ordinance

ITEM 12 Consent Agenda

1. Approval of Minutes (01.22.19)
2. Public Health Division - Purchase the Shingles Vaccine (Shingrix)
3. Sanitation - Budget Amendment to increase Container Purchases line item
4. Water Dept - NCDOT Right of Way Encroachment Agreement, 1182 Duck Road
5. Water Dept - NCDOT Right of Way Encroachment Agreement, Barley Lane, Frisco
6. Water Department Budget Amendment
7. Advertise 2018 Tax Year Liens

(Continued on other side)

- ITEM 13** Board Appointments
1. Aging Advisory Council
 2. Older Adult Services Advisory Council
 3. Planning Board
 4. Senior Tar Heel Legislature Delegates
 5. Upcoming Board Appointments

ITEM 14 Commissioners' Business & Manager's/Attorney's Business

ADJOURN UNTIL 5:00 P.M. ON TUESDAY, FEBRUARY 19, 2019



Opening Remarks - Chairman's Update

Description

Dare County Chairman Robert Woodard will make opening remarks.

Board Action Requested

Informational Presentation

Item Presenter

Chairman Robert Woodard



Presentation of County Service Pins - February 2019

Description

The following employees are scheduled to receive service pins this month:

1. Debra Perrot, Community Social Services Technician, 10 Year Pin
2. Kenneth Brite, Emergency Medical Technician Lieutenant, 15 Year Pin
3. John Cleaver, Leisure Activity Specialist, 15 Year Pin

Board Action Requested

None

Item Presenter

Robert Outten, County Manager

Presentation of County Service Pins

1. Debra Perrot, Community Social Services Technician – 10 Year Pin
Presented by Chuck Lycett
2. Kenneth Brite, Emergency Medical Tech Lieutenant - 15 Year Pin
Presented by Jenny Collins
3. John Cleaver, Leisure Activity Specialist – 15 Year Pin
Presented by Tim White



Employee of the Month

Description

The Employee of the Month Certificate will be presented.

Board Action Requested

None

Item Presenter

To Be Determined.



Public Comments

Description

The Board of Commissioners encourages citizen participation and provides time on the agenda at every regularly scheduled meeting for Public Comments. This is an opportunity for anyone to speak directly to the entire Board of Commissioners for up to five minutes on any topic or item of concern.

Comments can be made at the Commissioners Meeting Room in Manteo or through an interactive video link at the Fessenden Center Annex in Buxton.

Commissioners Meeting Room - Administration Building, 954 Marshall Collins Drive, Manteo
Video Link - Fessenden Center Annex, 47017 Buxton Back Road, Buxton

Board Action Requested

Hear Public Comments

Item Presenter

Robert Outten, County Manager



Report from the National Park Service

Description

Superintendent David Hallac will give the Board an update on National Park Service operations in Dare County and thank the community for their assistance during the recent federal government shutdown.

Board Action Requested

None - Information Presentation

Item Presenter

Superintendent David Hallac



Board of Commissioners Resolution Supporting Juvenile Crime Prevention Council Allocation Expansion

Description

The JCPC funding comes into Dare County as an allocation; it represents a partnership between the state and local community to ensure appropriate programming for children at-risk and those involved with the juvenile justice system. Up Until the passing of Raise the Age legislation in the summer of 2017, the focus of JCPC programming has been children up to the age of 16 years. Dec.1, 2019, the age of jurisdiction will include 16-17 year olds for misdemeanor and non-violent felony offenses, and JCPC programs will need to be prepared to serve referrals for that age. Funding has remained the same for over nine years, & with new referrals that will most definitely need services, additional JCPC funding is needed across the state to ensure programs have the capacity and training to adequately deliver services to this population. Support of the Resolution will align Dare with counties across the state to ensure the legislature members are aware of the need for additional funding.

Board Action Requested

Juvenile Crime Prevention Council seeks support and approval from the Dare County Board of Commissioners for the Attached Resolution.

Item Presenter

Bonnie Bennett, Treasurer of the JCPC - introducing Mrs. Fields
Ella Fields-Bunch, JCPC Area Consultant - will give an overview of the Resolution.

**DARE COUNTY
BOARD OF COMMISSIONERS**

**Board of Commissioners Resolution
Supporting
Juvenile Crime Prevention Council Allocation Expansion**

WHEREAS, Juvenile Crime Prevention Council (JCPC) funding is a partnership between the State of North Carolina and the County to ensure a local continuum of services for court involved and at-risk juveniles; and,

WHEREAS, Dare County JCPC funded programs, more specifically, completed services to 99 children last fiscal year at an average cost of \$2,100 per child with over 2150 hours of service provided, and having served over 600 children in just the past seven years while funding levels have continued to remain flat; and,

WHEREAS, the Juvenile Crime Prevention Council, under the authority of NCGS§143B-851, and within the scope of its powers and duties, "Each County Council shall annually review the needs of juveniles in the county who are at risk of delinquency or who have been adjudicated undisciplined or delinquent and the resources available to address those needs;" and,

WHEREAS, the Juvenile Justice Reinvestment Act passed in 2017, also referenced as North Carolina's Raise the Age legislation, expands the age of juvenile jurisdiction, increasing it to include juveniles ages 16 and 17 years of age effective December 1, 2019; and,

WHEREAS, Raise the Age legislation will increase the need for immediate and age-appropriate sanctions and diversion services for juvenile offenders and those at-risk of delinquency; and,

WHEREAS, JCPC funding has seen no increase in more than nine years; and,

WHEREAS, the effort to immediately and effectively address juvenile offending behavior is an evidence-based investment in North Carolina's future; and,

WHEREAS, effective intervention and programming reduces detention and youth development commitments as a cost savings to the state and county;

NOW, THEREFORE BE IT RESOLVED, that Dare County fully supports an adequate and timely increase of local Juvenile Crime Prevention funding to ensure program expansion and successful implementation of the Juvenile Justice Reinvestment Act Raise the Age Legislation, set for December 1, 2019.

Adopted this _____ day of _____ 2018.

Chairman

Clerk to the Board



Dare County N.C. Cooperative Extension Report to the People

Description

Short presentation illustrating Extension's 2018 accomplishments.

Board Action Requested

Short presentation illustrating Extension's 2018 accomplishments.

Item Presenter

Shannon Brooks, Dare County Extension Director

Dare County NC Cooperative Extension 2018

Volunteerism

We believe in solving problems through service and we love volunteers!

- 114 Volunteers
- 8,777 Contacts
- 5955 Hours of Service
- \$147,029 National Economic Value of Volunteer Services

Education

We believe in life-long learning!

- 62 Educational Programs
- 7873 People Attended
- 229 Hours of Instruction
- \$4190 Secured for 4-H and Nutrition Programs
- Home Horticulture Programs Funded by 501(c)(3) Dare Master Gardener Volunteer Association

Partnerships

We believe working together creates more opportunities for positive change!

- Dare County Commissioners and NCACC
- Towns of Manteo and Kill Devil Hills
- Coastal Studies Institute
- Dare County EMS
- Outer Banks Beekeepers' Guild
- Coastal Federation
- Jockey's Ridge State Park
- Dunes of Dare Garden Club and Roanoke Island Garden Club
- The Elizabethan Gardens
- PATH homeschool cooperative
- Mano al Hermano
- Dare County Head Start
- 5 community gardens
- Tyrrell, Currituck, Camden, Hyde, Pasquotank Counties
- Dare County entities such as Dare County Libraries, Public Health & Human Services, Thomas A. Baum Senior Center, The Dare Center, Friends of Youth, All Summer Enrichment Program, Manteo High School and more.

Thank you for your support of Dare County NC Cooperative Extension!

Donna Hanusik, Administrative Assistant
Amy Jordan, Agricultural Technician Program Assistant
Paige Fuselier, 4-H Agent
Dee Furlough, Family and Consumer Science Agent
Shannon Brooks, County Extension Director and Horticulture Agent



2018 NC Cooperative Extension Highlights

- **Family & Consumer Science** Agent Dee Furlough is an award winning Agent who delivers nationally recognized curriculum designed to encourage healthy eating, increased physical activity and chronic disease reduction. The Med Instead of Meds series, Heart Healthy Lunch, Eat to Beat Diabetes, Home Preservation of Local Foods, and Cooking with Herbs were among the many classes she taught this year.
- The **Extension Community Association** (ECA) works to strengthen families through leadership development and volunteerism. In 2018, 12 members provided over 300 hours of service to Dare County.
- **4-H** Agent Paige Fuselier captivated new audiences with hands-on learning workshops for kids such as Farm to Fork, Electric Workshop, How to be a Scientist, Babysitter's Backpack, Honey Hunting, Let's Go Kayaking, and Service & Citizenship. She also provided opportunities for Dare County kids to attend state and regional events. She has been working to raise additional funding and support new 4-H clubs focusing on shooting sports and horticulture. She has recruited 37 adult volunteers and 2 youth volunteers.
- County Extension Director Shannon Brooks provided one-on-one consultations and programming in **horticulture for homeowners**. Topics focused on practices that save people money, help our environment, and preserve our beautiful landscape. Topics this year included Organic Gardening, Coastal Gardening, Container Gardening and more.
- For **commercial landscapers**, Brooks provides one-on-one consultations and pesticide education. She continues to provide opportunities for pesticide testing, pesticide collections, regional workshops for licensing credits, soil testing, weed and insect identification, and nematode and disease testing. This year, she co-hosted the Northeast North Carolina Landscape Conference with two other Horticulture Agents at the Vernon James research facility.
- Amy Jordan is the newest staff person and a most excellent manager of the Dare County **Extension Master Gardener Volunteer** program. In 2018, just 63 Master Gardeners provided 5,482 hours of service to local citizens. Three of their programs won state recognition in 2018, earning two 1st place and one 2nd place *Search for Excellence* awards. Master Gardeners provide one-on-one consultations, hands-on workshops, programming on local television, and library teaching programs from Corolla to Buxton. They also host annual fun, educational events such as the Coastal Gardening Festival attended by over 3,000 people each spring and outdoor, hands-on workshops in the OBX Arboretum and Teaching Garden.
- The **Dare Master Gardener Volunteer Association** 501(c)(3) held multiple successful fundraisers. Funds support Dare County's Extension Master Gardener Volunteers and their educational programs, including the maintenance of the first-rate OBX Arboretum & Teaching Garden visited by thousands of people each year.

NC State University and N.C. A&T State University commit themselves to positive action to secure equal opportunity and prohibit discrimination and harassment regardless of age, color, disability, family and marital status, genetic information, national origin, political beliefs, race, religion, sexual identity (including pregnancy) and veteran status. NC State, N.C. A&T, U.S. Department of Agriculture, and local governments cooperating.





OT Enterprises -- Conditional Use Permit for Cluster Home Development

Description

A site plan and conditional use permit application has been submitted by OT Enterprises for construction of a cluster home development in Avon, NC. The site plan, staff report, and draft conditional use permit are attached with this cover sheet.

Board Action Requested

Approval of draft CUP and site plan. "I move the proposed cluster home development and site plan submitted by OT Enterprises be approved as recommended by the Planning Board."

Item Presenter

Donna Creef, Planning Director

STAFF REPORT – February 4, 2019 Board of Commissioners Meeting

FROM: Donna Creef, Planning Director

RE: Conditional Use Permit Application – OT Enterprises – Cluster Home Development

A site plan and conditional use permit application have been submitted by OT Enterprises for a cluster home development in Avon, NC. The proposed site is zoned C-2, commercial and is identified as Parcel A of the Hatteras Island Plaza Subdivision. The proposal is the first site plan submitted for a cluster home development according to Section 22-31.1 of the Dare County Zoning Ordinance. Section 22-31.1 was recently added to the Dare County Zoning Ordinance in an effort to facilitate development of year-round housing opportunities. The site improvements will provide employee housing for the tenants of Hatteras Island Plaza. The owners of the site have been working for some time to develop the parcel for employee housing.

The property is located in behind the Hatteras Island shopping center and will feature three 3-bedroom structures and associated parking. The site is connected to the Kinnakeet Shores central wastewater system. There is a pond and wetland area on the site as noted on the site plan and narrative provided by Quible and Associates.

Section 22-31.1 limits the size of each structure to 1200 square feet of conditioned space. The footprint for each site is 24'.2" x 20' which is consistent with this limitation. Three parking spaces will be provided for each structure. The developers understand that the units cannot be used for short-term occupancy or rental (less than 30 days). This requirement is included with the other conditions in the draft CUP attached to my memorandum. The CUP will be recorded in the Register of Deeds with the site plan.

The proposed improvements have been reviewed by the Fire Marshal and condition #6 in the draft CUP reflects his review. A time period of 24 months to secure building permits for the three structures is also included in the CUP.

The Planning Board reviewed this proposal at their January 14, 2019 meeting and voted unanimously to recommend approval.

Conditional Use Permit Narrative

Parcel A, Hatteras Island Plaza – Avon, Dare County, NC
December 17, 2018



Overview

Parcel A, Hatteras Island Plaza is currently a vacant parcel with a total parcel area of approximately 1.17 acres. The total parcel area includes approximately 0.34 acres of wetlands, and approximately 0.48 acres of an existing pond. The parcel is located within General Commercial (C-2) zoning.

The proposed use of the property includes three, three-bedroom dwelling units, and the site plan was developed in accordance with the dimensional requirements for the High-Density Residential District (R-3). A Conditional Use Permit is being requested to allow for the cluster home development use in compliance with Section 22-31.1 of the Dare County Code of Ordinances.

The proposed project includes the construction of three, three-bedroom dwelling units with dimensions of approximately 42 ft. x 24.2 ft. each ($\pm 1,016.4$ sq. ft.), associated parking and drive, and utility installation and connections. Proposed impervious coverage counting toward lot coverage includes buildings with associated decks/stairs, and concrete for a total proposed lot coverage of 4,412 sq. ft. (14.6%). Please note that the existing pond area was excluded from the total parcel area when calculating the coverage percentage.

Access and Parking

The proposed dwelling units and associated parking spaces are to be accessed by a proposed 10 ft. wide gravel drive connecting to the existing paved access within Hatteras Island Plaza. The parking requirements were calculated based on one required parking space per bedroom. Nine parking spaces are required for the development, and nine parking spaces are provided. Five of the nine provided parking spaces are paved with concrete, resulting in greater than 50% of the required parking spaces being of an impervious surface.

Stormwater Management / Soil Erosion and Sedimentation Control

A state stormwater management permit through NCDEQ is not required for the project, due to the proposed coverage being less than 10,000 sq. ft.

A state soil erosion and sedimentation control permit through NCDEQ is not required, due to the proposed limits of disturbance being less than one acre; however, soil erosion and sedimentation control measures have been included in the site plan.

Utilities

Water: Water service for the project is proposed by connecting to the existing Dare County water main along the northern end of the property.

Wastewater: Wastewater service for the project is proposed by connecting to the existing Kinnakeet Shores Wastewater Collection System, with treatment and disposal provided by the existing Kinnakeet Shores Wastewater Treatment Plant.

Power: The power for the proposed dwelling units shall be provided by ~~Dominion Power~~.

Cape Hatteras
Electric

NOTES:

- OWNER/APPLICANT: C. BRANTLEY TILLMAN, JR & R V OWENS III
1004 WAKE FOREST RD
C/O COMMERCIAL PROPERTIES INC
RALEIGH, NC 27604
- PN# 0549-0915-1025
PID# 014822270
PROPERTY ADDRESS: 0 NC 12 HWY
- RECORDED REFERENCE: DB 1607, PG 244; PC F, SL 375
- PROPERTY ZONED: GENERAL COMMERCIAL (C-2)
- SETBACKS AS PER DARE COUNTY ZONING ORDINANCE FOR RESIDENTIAL STRUCTURES IN THE C-2 ZONE; SEE R-3 DIMENSIONAL REQUIREMENTS. SETBACKS MUST BE VERIFIED WITH DARE COUNTY PLANNING.
FRONT 25'
SIDE 8'
SIDE STREET 16'
REAR 20'
- TOTAL PARCEL AREA: 50,920.10 SQ. FT. (1.17 ACRES)
UPLANDS = 15,314.48 SQ. FT. (0.35 ACRES)
WETLANDS = 14,854.85 SQ. FT. (0.34 ACRES)
POND = 20,750.77 SQ. FT. (0.48 ACRES)
- LOT COVERAGE:
EXISTING LOT COVERAGE:
GRAVEL = 141 SQ. FT. (NOT COUNTED TOWARD COVERAGE)
TOTAL EXISTING LOT COVERAGE = 0 SQ. FT.
PROPOSED LOT COVERAGE:
BUILDINGS = 3,049 SQ. FT.
DECKS = 308 SQ. FT.
CONCRETE = 1,057 SQ. FT.
GRAVEL = 4,250 SQ. FT. (NOT COUNTED TOWARD COVERAGE)
TOTAL PROPOSED LOT COVERAGE = 4,412 SQ. FT.
(MAXIMUM COVERAGE ALLOWED = 30%)
NOTE: POND AREA EXCLUDED FROM PARCEL AREA WHEN CALCULATING COVERAGE PERCENTAGE.
- MAXIMUM HEIGHT = 35'
- PARKING SPACES REQUIRED = 1 SPACE PER BEDROOM = 9 SPACES
- PROPERTY IS LOCATED IN NFIP FLOOD ZONE AE (EL. 8') AND SUBJECT TO CHANGES BASED ON COMMUNITY CD NO. 375348; PANEL 0549; SUFFIX J. (MAP NUMBER 3730054900J). EFFECTIVE DATE: 09/20/2006.
- BOUNDARY INFORMATION SHOWN BASED UPON PC F, SL 375, AND FIELD SURVEY BY QUIBLE & ASSOCIATES, P.C., DATED 12/14/2017.
- TOPOGRAPHIC INFORMATION SHOWN BASED UPON FIELD SURVEY BY QUIBLE & ASSOCIATES, P.C., DATED 12/14/2017.
- THIS PLAN SUBJECT TO ANY FACTS, INCLUDING BUILDING SETBACK RESTRICTIONS, EASEMENTS, COVENANTS, ETC., THAT MAY BE REVEALED BY A FULL AND ACCURATE TITLE SEARCH.
- WATER SERVICE PROVIDED BY DARE COUNTY WATER DEPARTMENT. ALL WATERLINE INFRASTRUCTURE SHALL COMPLY WITH DARE COUNTY STANDARD SPECIFICATION FOR WATER DISTRIBUTION CONSTRUCTION.

WASTEWATER SYSTEM NOTES:

- CONTRACTOR IS RESPONSIBLE FOR LOCATING EXISTING UNDERGROUND UTILITIES IN AREAS OF WORK PRIOR TO ANY WORK. PROVIDE ADEQUATE MEANS OF SUPPORT AND PROTECTION IF UTILITIES ARE TO REMAIN IN PLACE.
- REMOVE TREES, GRASSES, SHRUBS AND OTHER VEGETATION, IMPROVEMENTS OR OBSTRUCTIONS INTERFERING WITH INSTALLATION OF NEW CONSTRUCTION UNLESS NOTED OTHERWISE.
- WASTEWATER TREATMENT VIA CONNECTION TO KINNAKEET SHORES WASTEWATER COLLECTION SYSTEM.
DESIGN FLOW: 120 GALLONS PER DAY (GPD) PER BEDROOM X 9 BEDROOMS = 1,080 GPD
ANY PERMIT MODIFICATIONS, EXTENSION PERMITS, EASEMENTS, ETC., REQUIRED BY THE DOWNSIDE SEWER AUTHORITY SHALL BE OBTAINED PRIOR TO CONSTRUCTION.
- UNLESS OTHERWISE INDICATED ON THE PLAN, CONSTRUCTION OF SEWAGE COLLECTION, TREATMENT AND DISPOSAL SYSTEM IS TO CONFORM WITH SECTIONS 0100, 0300 AND 0400 "WASTE NOT DISCHARGED TO SURFACE WATERS" OF NORTH CAROLINA ADMINISTRATIVE CODE, TITLE 15A DEPARTMENT OF ENVIRONMENTAL QUALITY DIVISION OF WATER RESOURCES.
- CONSTRUCTION OF SEWAGE COLLECTION SYSTEM, TREATMENT AND DISPOSAL SYSTEM IS TO CONFORM WITH ANY CONDITIONS IMPOSED BY THE UTILITY COMPANY SERVING THE KINNAKEET SHORES WASTEWATER COLLECTION SYSTEM, THE LOCAL HEALTH DEPARTMENT, AND/OR NORTH CAROLINA DEPARTMENT OF ENVIRONMENTAL QUALITY DIVISION OF WATER RESOURCES, AS APPROPRIATE. PROPOSED SANITARY SEWER INFRASTRUCTURE SHALL BE INSPECTED BY A REPRESENTATIVE OF THE KINNAKEET SHORES WASTEWATER SYSTEM.
- MATERIAL USED FOR COLLECTION AND DISPOSAL SYSTEM SHALL CONFORM WITH SAME REQUIREMENTS AS #4 ABOVE.
- CHANGES IN NEW PIPING OR STRUCTURES FROM THAT SHOWN ON THE DRAWINGS, IN ORDER TO AVOID CONFLICTS WITH EXISTING ELECTRICAL SYSTEMS, MECHANICAL SYSTEMS, EQUIPMENT, STRUCTURES, OR EXISTING PIPING SHALL BE THE RESPONSIBILITY OF THE CONTRACTOR. WHETHER THE CONFLICTS ARE SHOWN OR ARE DISCOVERED IN THE FIELD, LIKEWISE, ALTERATIONS TO EXISTING ELECTRICAL SYSTEMS, MECHANICAL SYSTEMS, EQUIPMENT, OR EXISTING PIPING IN ORDER TO ACCOMMODATE NEW PIPING, STRUCTURES AND EQUIPMENT, SHALL BE THE RESPONSIBILITY OF THE CONTRACTOR AT NO ADDITIONAL COST TO THE OWNER. THE OWNER AND THE ENGINEER MUST APPROVE ALL SUCH CHANGES.
- MAINTAIN AND PROTECT ALL OVERHEAD AND UNDERGROUND ELECTRICAL, TELEPHONE, CABLE TV, WATER, AND ALL OTHER UTILITIES DURING ENTIRE CONSTRUCTION PERIOD. WATER SERVICE INTERRUPTIONS AND OTHER UTILITY OUTAGES WILL NOT BE ALLOWED.
- PROVIDE A MINIMUM OF 18 INCHES CLEARANCE BETWEEN PIPING AND FOOTINGS, STRUCTURES, AND OTHER PIPING UNLESS OTHERWISE INDICATED. A POSITIVE GRADE SHALL BE MAINTAINED FOR THE VERTICAL ALIGNMENT OF ALL WATER AND SEWER PIPING TO ELIMINATE THE FORMATION OF AIR POCKETS.
- HORIZONTAL DISTANCE IS INDICATED FOR ALL PROPOSED PIPE LENGTHS SHOWN ON THE DRAWINGS. DEFLECT PIPE JOINTS AS REQUIRED TO MAINTAIN WATERLINE AND SEWER ALIGNMENTS SHOWN. THE CONTRACTOR SHALL PROVIDE ALL PIPE FITTINGS AS REQUIRED FOR COMPLETE AND OPERABLE PIPE INSTALLATIONS.
- CONTRACTOR SHALL PROVIDE ALL CONNECTING PIPES AND TRANSITION PIECES REQUIRED TO MAKE FINAL PIPING CONNECTIONS.
- SURFACE DRAINAGE: COMPLETELY DRAIN CONSTRUCTION SITE DURING PERIODS OF CONSTRUCTION TO KEEP SOIL MATERIALS SUFFICIENTLY DRY. PROVIDE TEMPORARY DITCHES, SWALES, AND OTHER DRAINAGE FEATURES AND EQUIPMENT AS REQUIRED TO MAINTAIN DRY SOILS. WHEN UNSUITABLE WORKING PLATFORMS FOR EQUIPMENT OPERATION AND UNSUITABLE SOIL SUPPORT FOR SUBSEQUENT CONSTRUCTION FEATURES DEVELOP, REMOVE UNSUITABLE MATERIAL AND PROVIDE NEW SOIL MATERIAL AT NO ADDITIONAL COST TO THE OWNER.
- SUBSURFACE DRAINAGE: CONSIDER SITE SURFACE AND SUBSURFACE CONDITIONS, AVAILABLE SOIL, AND HYDROLOGICAL DATA. REMOVE WATER BY BENCHING, SUMP PUMPING, OR OTHER METHODS TO PREVENT SOFTENING OF SURFACES EXPOSED BY EXCAVATION. USE FILTERS ON DEWATERING DEVICES TO PREVENT REMOVAL OF FINES FROM SOIL. PROVIDE EROSION CONTROL AT OUTLET OR PIPING TO PREVENT EROSION. OPERATE DEWATERING SYSTEM CONTINUOUSLY UNTIL CONSTRUCTION WORK BELOW EXISTING WATER LEVELS IS COMPLETE.
- CONSTRUCT EXCAVATION SUPPORT SYSTEMS AS REQUIRED BY OSHA AND U.S. ARMY CORPS OF ENGINEERS SAFETY AND HEALTH REQUIREMENT MANUAL EM 385-1-1, SECTION 25 AS A THROUGH E TO ADEQUATELY SUPPORT EXISTING SOIL AND ADJACENT STRUCTURES DURING EXCAVATION ACTIVITIES.

SOIL EROSION & SEDIMENTATION CONTROL PLAN NOTES:

- AREA TO BE DISTURBED: 111,397 SQ.FT. (±0.26 ACRES)
- PROVIDE A GROUND COVER STABILIZATION (TEMPORARY OR PERMANENT) ON ALL DENUDED DOWNSIDE SURFACES FOLLOWING THE COMPLETION OF LAND DISTURBING ACTIVITIES PER THE CRITERIA LISTED BELOW:
 - PERIMETER DIKES, BERMS, SWALES, DITCHES AND SLOPES SHALL BE STABILIZED IN 7 DAYS.
 - HIGH QUALITY WATER (HOW) ZONES SHALL BE STABILIZED IN 7 DAYS.
 - DOWNSIDE SLOPES STEEPER THAN 3:1 SHALL BE STABILIZED IN 7 DAYS. IF SLOPES ARE 10' OR LESS AND ARE NOT STEEPER THAN 2:1, 14 DAYS ARE ALLOWED.
 - DOWNSIDE SLOPES 3:1 OR FLATTER AND LESS THAN 50' IN LENGTH SHALL BE STABILIZED IN 14 DAYS. SLOPES 3:1 OR FLATTER EXCEEDING 50' IN LENGTH SHALL BE STABILIZED IN 7 DAYS.
 - ALL OTHER DOWNSIDE AREAS WITH SLOPES 4:1 OR FLATTER SHALL BE STABILIZED WITHIN 14 DAYS.
 - GROUND COVER SHALL BE PROVIDED ON CUT AND FOR FILL SLOPES WITHIN 21 CALENDAR DAYS AFTER COMPLETION OF ANY PHASE OF GRADING. GROUND COVER OVER OTHER AREAS SHALL BE PROVIDED WITHIN SHORTER OF 15 WORKING OR 90 CALENDAR DAYS (60 DAYS IN HOW ZONES) OF COMPLETION OF CONSTRUCTION OF DEVELOPMENT.
- IF LAND DISTURBING ACTIVITIES OCCUR OUTSIDE THE PERMANENT VEGETATION SEEDING DATES (APR. 1-SEP. 30) THEN TEMPORARY VEGETATION SEEDING SPECIFICATIONS SHALL BE FOLLOWED FOR PLANTING UNTIL THE NEXT APPROPRIATE PERMANENT SEEDING PERIOD, AT WHICH TIME PERMANENT VEGETATION SHALL BE ESTABLISHED ACCORDING TO PERMANENT VEGETATION SEEDING SPECIFICATIONS (SEE PERM. & TEMP. SEEDING SPECIFICATIONS).
- IF EXCESSIVE WIND EROSION OR STORMWATER RUNOFF EROSION DEVELOPS DURING TIME OF CONSTRUCTION ANY LOCATION ON THE PROJECT SITE, ADDITIONAL EROSION AND SEDIMENTATION CONTROL MEASURES SHALL BE INSTALLED IMMEDIATELY AS DIRECTED BY THE ENGINEER TO ADDRESS THE PROBLEM AREA AND PREVENT DAMAGE TO ADJACENT PROPERTIES.
- SOIL EROSION AND SEDIMENTATION CONTROLS TO BE INSPECTED, MAINTAINED AND REPAIRED AS NECESSARY UNTIL PERMANENT CONTROLS ARE ESTABLISHED.
 - A RAIN GAUGE MUST BE KEPT ON SITE.
 - DEDICATED DEMOLITION AND OTHER WASTE AREAS AND EARTHEN MATERIAL STOCKPILES MUST BE LOCATED AT LEAST 50 FEET FROM DRAINS OR STREAMS UNLESS ALTERNATIVE IS FEASIBLE.
 - ALL EROSION AND SEDIMENT CONTROL MEASURES MUST BE INSPECTED AT LEAST ONCE A WEEK AND WITHIN 24 HOURS AFTER ANY STORM EVENT GREATER THAN A HALF INCH (DURING A 24 HOUR PERIOD). IMMEDIATE CORRECTIVE ACTION MUST BE TAKEN FOR ANY DEVICE FAILURE.
 - INSPECT ALL OUTLETS WHERE RUNOFF LEAVES SITE AND EVALUATE EFFECT ON NEARBY STREAMS. TAKE CORRECTIVE ACTION IF NECESSARY.
 - MAINTAIN RECORDS OF INSPECTIONS AND CORRECTIVE ACTIONS.
 - EARTHWORK NOTE: OFFSITE BORROW MATERIAL SHALL COME FROM AN NCDCE DIVISION OF ENERGY, MINERAL AND LAND RESOURCES APPROVED SITE. OFFSITE DISPOSAL OF EXCESS MATERIAL SHALL BE TO AN NCDCE DIVISION OF ENERGY, MINERAL AND LAND RESOURCES APPROVED SITE.

CONSTRUCTION SEQUENCE:

- PRECONSTRUCTION:
- OBTAIN PLAN APPROVAL AND OTHER APPLICABLE PERMITS.
 - FLAG AND/OR ROUGH STAKE WORK LIMITS.
 - FLAG EXISTING VEGETATION TO REMAIN/PROTECT.
 - HOLD PRECONSTRUCTION CONFERENCE (OWNER, CONTRACTOR, ENGINEER, AND APPROPRIATE GOVERNMENT OFFICIALS) AT LEAST ONE WEEK PRIOR TO START OF CONSTRUCTION ACTIVITIES.
- CONSTRUCTION:
- INSTALL CONSTRUCTION ENTRANCE AND SILT FENCING AT LOCATIONS SHOWN ON PLAN.
 - COMPLETE CLEARING, GRUBBING AND DEMOLITION PROCEDURES.
 - INSTALL CONTRIBUTING STORM CONVEYANCES AND ASSOCIATED EROSION CONTROLS.
 - GRADE SITE ACCORDING TO PLAN AND BEGIN CONSTRUCTION OF PROPOSED IMPROVEMENTS, INCLUDING UTILITY CONNECTIONS.
 - COMPLETE FINAL GRADING OF THE GROUNDS, TOPSOIL, PERMANENTLY SEED, LANDSCAPE, AND MULCH.
 - ALL EROSION & SEDIMENTATION CONTROLS SHALL BE INSPECTED WEEKLY AND AFTER HEAVY RAINFALL EVENT. NEEDED REPAIRS AND MAINTENANCE WILL BE MADE IMMEDIATELY. FURTHERMORE, IF ANY WIND OR STORMWATER RUNOFF EROSION DEVELOPS DURING THE CONSTRUCTION OF THE PROJECT, ADDITIONAL EROSION AND SEDIMENTATION CONTROL MEASURES SHALL BE INSTALLED TO ADDRESS THE PROBLEM AREA.
 - ONCE THE SITE CONSTRUCTION IS COMPLETE AND DENUDED SURFACES ARE FULLY STABILIZED, ALL STORMWATER CONVEYANCES, STRUCTURES AND PIPING SHALL BE CLEANED OF ALL SILT/DEBRIS WHICH MAY HAVE ACCUMULATED DURING CONSTRUCTION. CONTRACTOR SHALL VERIFY DESIGN GRADES OF ALL STORMWATER CONVEYANCES AND RESTORE TO DESIGN SPECIFICATIONS AS NECESSARY.
 - UPON THE REMOVAL OF ACCUMULATED SEDIMENTS AND SITE STABILIZATION, ALL REMAINING EROSION CONTROLS MAY BE REMOVED FROM THE DEVELOPMENT. ALL DOWNSIDE EROSION CONTROLS SHALL REMAIN IN PLACE UNTIL THE COMPLETION OF ALL OTHER DEVELOPMENT CONSTRUCTION ACTIVITIES.

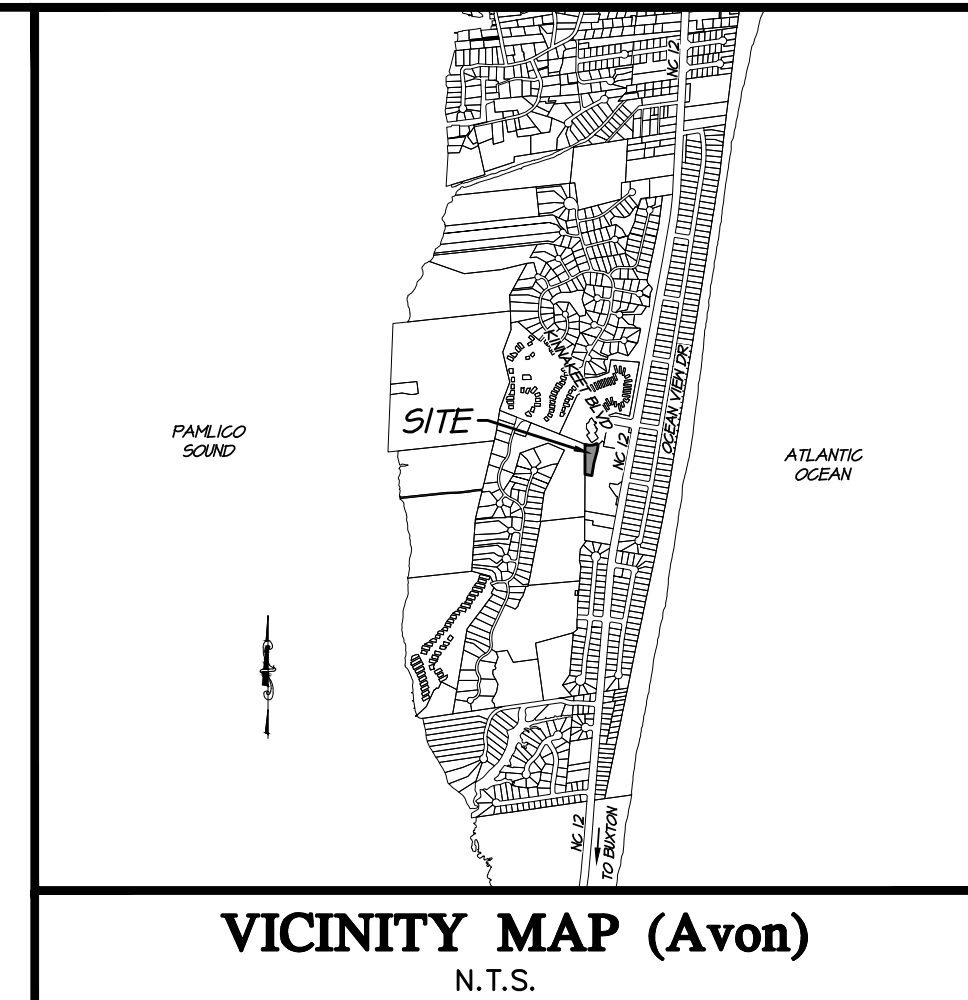

NC License# C-0208
SINCE 1959
Quible & Associates, P.C.
CONSTRUCTION SURVEYING
ENVIRONMENTAL SCIENCE SURVEYING
HYDROLOGICAL SURVEYING
8446 CAROLINA HWY. SUITE B
RALEIGH, NC 27617
Phone: (919) 981-9127
Fax: (919) 981-9146
www.quibleandassociates.com

REGISTERED PROFESSIONAL SURVEYOR
STATE OF NORTH CAROLINA
CERTIFICATION

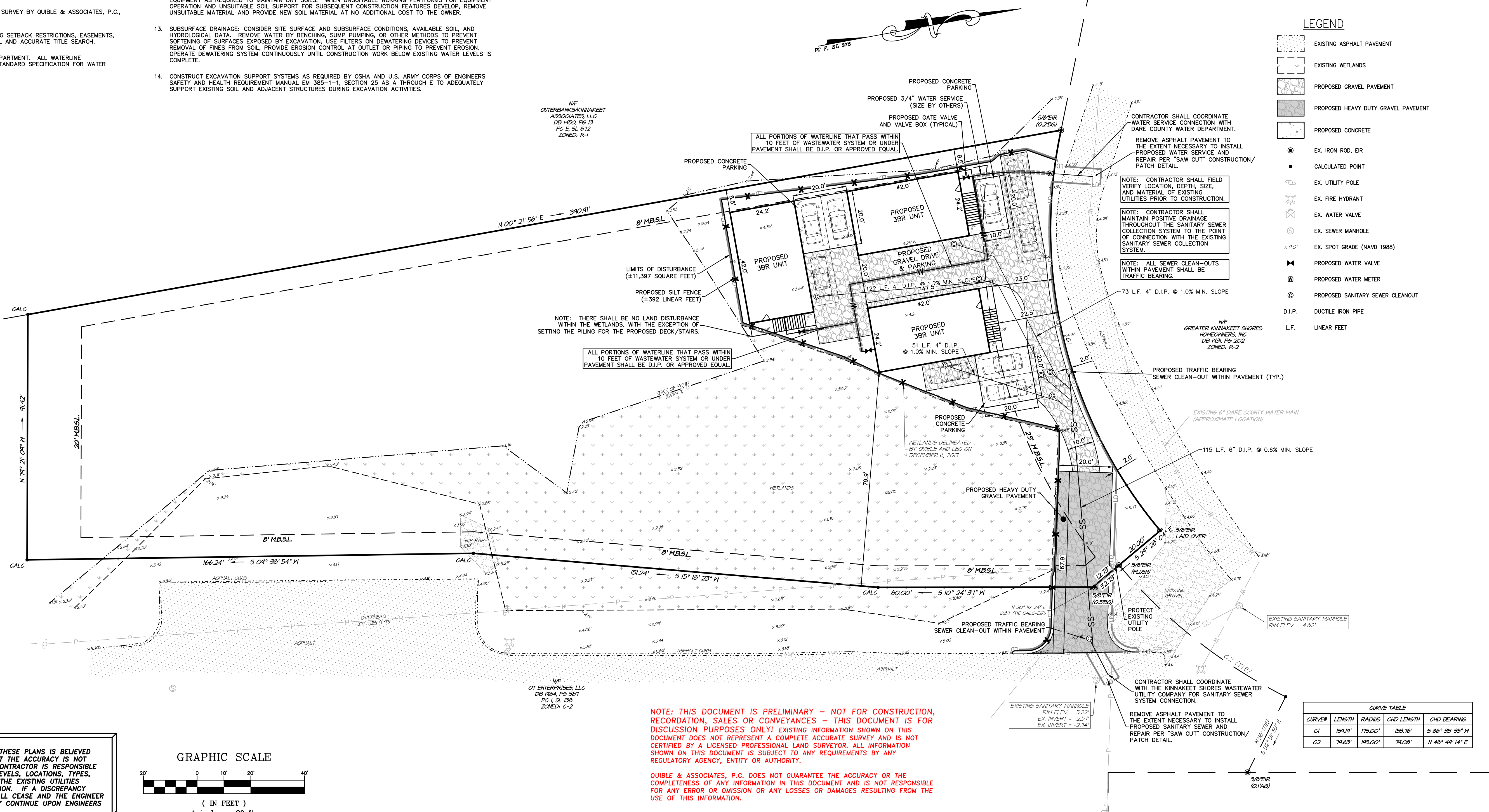

NOTE: THIS DOCUMENT IS PRELIMINARY - NOT FOR CONSTRUCTION, RECORDATION, SALES OR CONVEYANCES - THIS DOCUMENT IS FOR DISCUSSION PURPOSES ONLY! EXISTING INFORMATION SHOWN ON THIS DOCUMENT DOES NOT REPRESENT A COMPLETE ACCURATE SURVEY AND IS NOT CERTIFIED BY A LICENSED PROFESSIONAL LAND SURVEYOR. ALL INFORMATION SHOWN ON THIS DOCUMENT IS SUBJECT TO ANY REQUIREMENTS BY ANY REGULATORY AGENCY, ENTITY OR AUTHORITY.
QUIBLE & ASSOCIATES, P.C. DOES NOT GUARANTEE THE ACCURACY OR THE COMPLETENESS OF ANY INFORMATION IN THIS DOCUMENT AND IS NOT RESPONSIBLE FOR ANY ERROR OR OMISSION OR ANY LOSSES OR DAMAGES RESULTING FROM THE USE OF THIS INFORMATION.

811
Know what's below.
Call before you dig.

NOTE:
THE DATA GIVEN ON THESE PLANS IS BELIEVED TO BE ACCURATE, BUT THE ACCURACY IS NOT GUARANTEED. THE CONTRACTOR IS RESPONSIBLE FOR VERIFYING ALL LEVELS, LOCATIONS, TYPES, AND DIMENSIONS OF THE EXISTING UTILITIES PRIOR TO CONSTRUCTION. IF A DISCREPANCY IS FOUND, WORK SHALL CEASE AND THE ENGINEER NOTIFIED. WORK MAY CONTINUE UPON ENGINEERS NOTICE TO PROCEED.

REVISIONS

NO.	DATE	REVISIONS
1	01/16/19	REUSE SITE ACCESS PER PLANNING BOARD COMMENTS

SITE PLAN
PARCEL A, HATTERAS ISLAND PLAZA
C. BRANTLEY TILLMAN, JR & R V OWENS III
KINNAKEET TOWNSHIP DARE COUNTY NORTH CAROLINA

COMMISSION NO. P17120
DESIGNED BY BKH
DRAWN BY JTM/JMH/BKH
CHECKED BY MWS
ISSUE DATE 12/10/18
SHEET NO. 1 OF 2 SHEETS

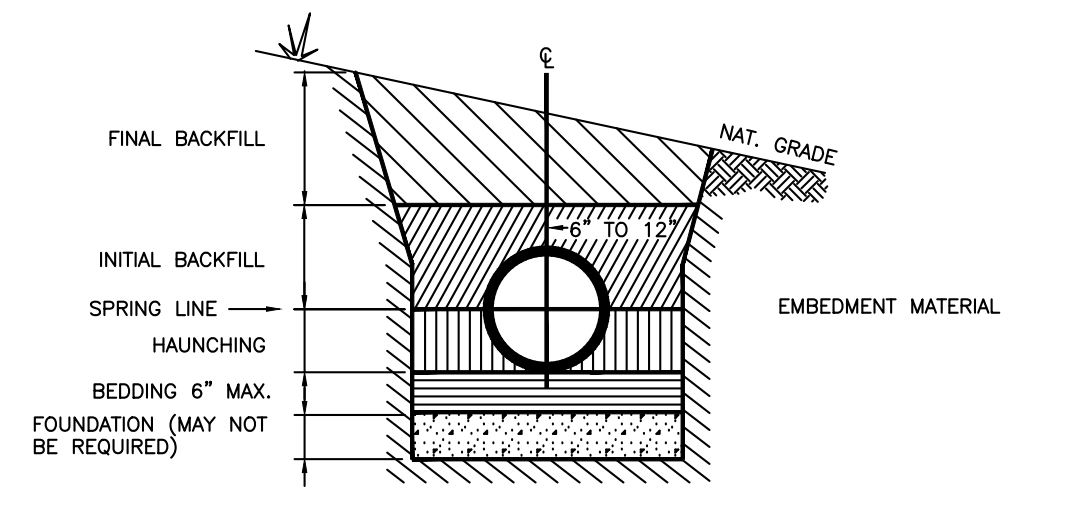

GRAVITY SEWER EMBEDMENT CONDITIONS FOR FLEXIBLE AND SEMI-RIGID SEWER PIPE
N.T.S.
PIPE INSTALLATION TO CONFORM TO ASTM D 2321

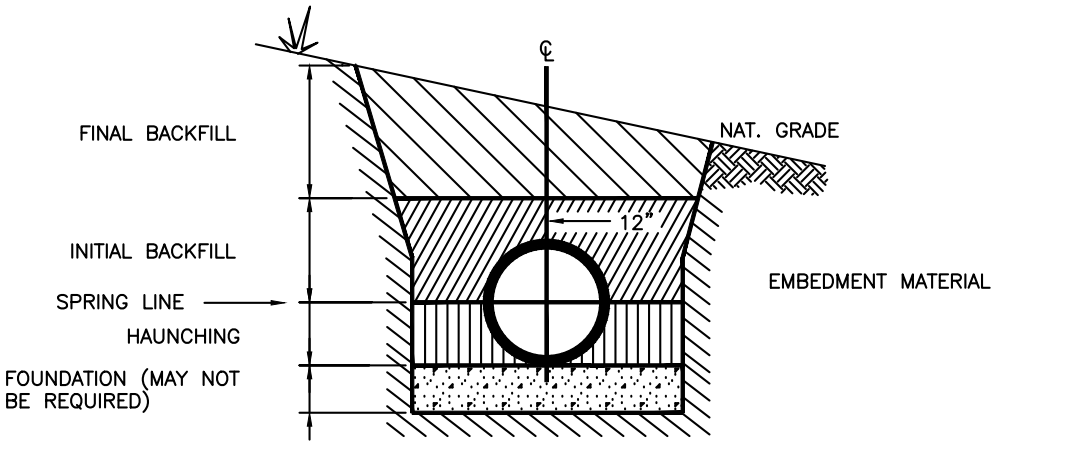

GRAVITY SEWER EMBEDMENT CONDITIONS FOR RIGID SEWER PIPE
N.T.S.
PIPE INSTALLATION TO CONFORM TO ASTM D 2321

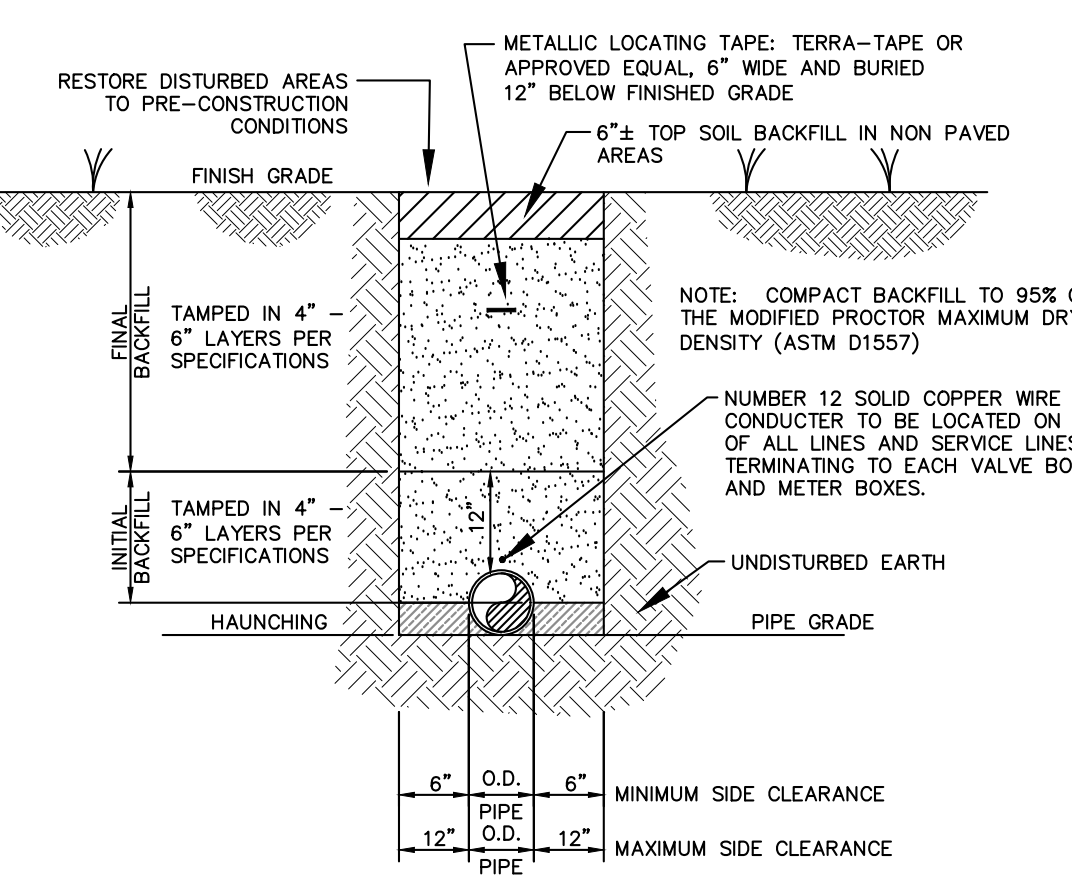

- NOTES:**
- FOR TRENCHES REQUIRING SHORING AND BRACING, DIMENSIONS SHALL BE TAKEN FROM THE INSIDE FACE OF THE SHORING AND BRACING.
 - NO ROCKS OR BOULDERS 4" AND LARGER SHALL BE USED IN INITIAL BACKFILL AREA.
 - ALL BACKFILL MATERIAL SHALL BE SATISFACTORY SOIL MATERIALS UNLESS OTHERWISE SPECIFIED BY THE ENGINEER. (SATISFACTORY SOIL FILL SHALL CONSIST OF SAND OR GRAVEL CONTAINING LESS THAN 20% BY WEIGHT OF FINES [SW, SP, SP-SM, SM], HAVING A LIQUID LIMIT LESS THAN 20 AND PLASTIC LIMIT LESS THAN 6, AND FREE OF RUBBLE, ORGANICS, CLAY, DEBRIS, AND OTHER UNSUITABLE MATERIAL.)

TYPICAL BACKFILLING REQUIREMENTS AND TRENCH BOTTOM DIMENSIONS
N.T.S.

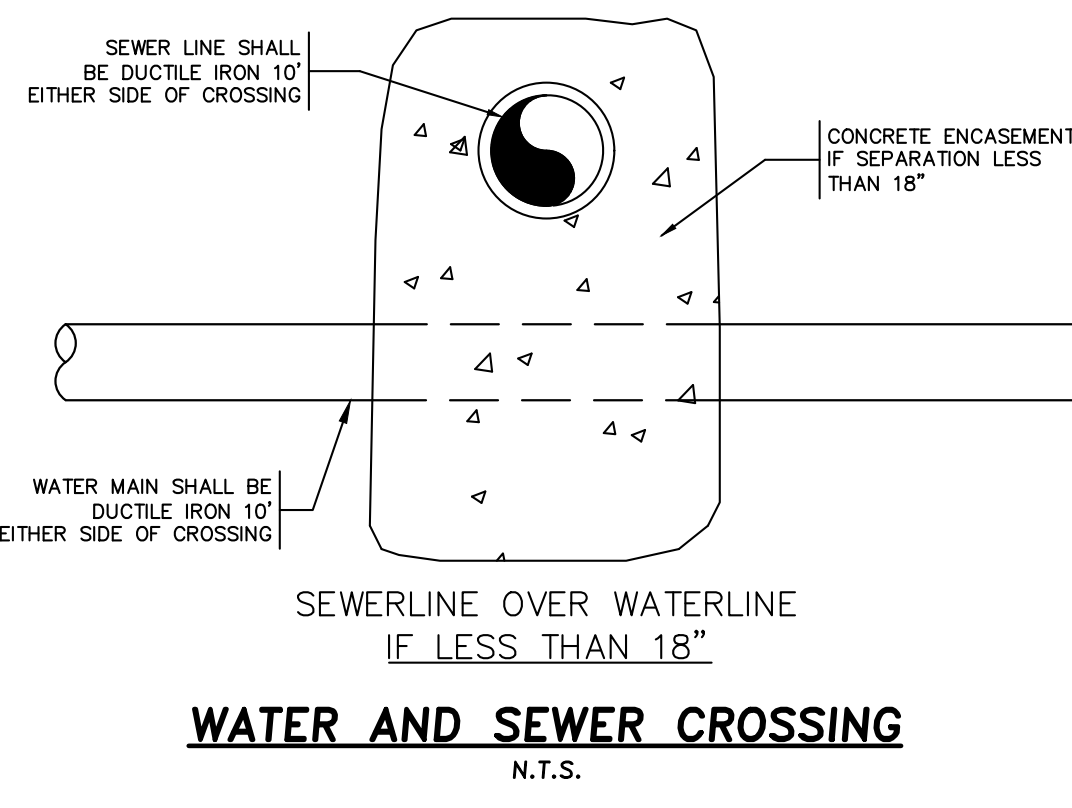
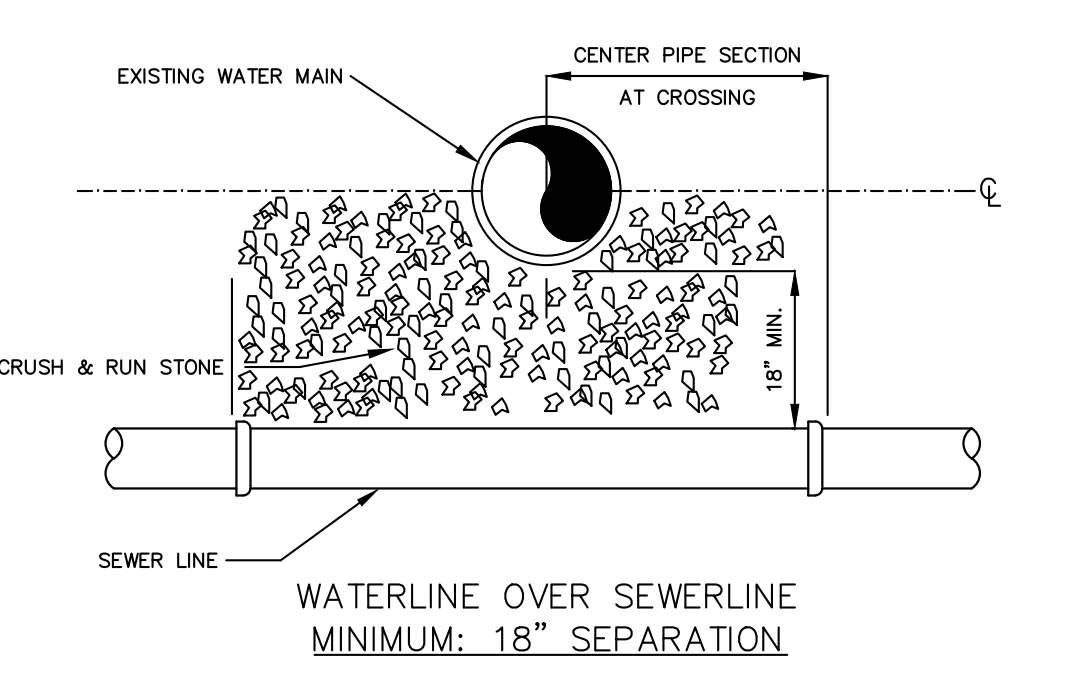

WATER AND SEWER CROSSING
N.T.S.

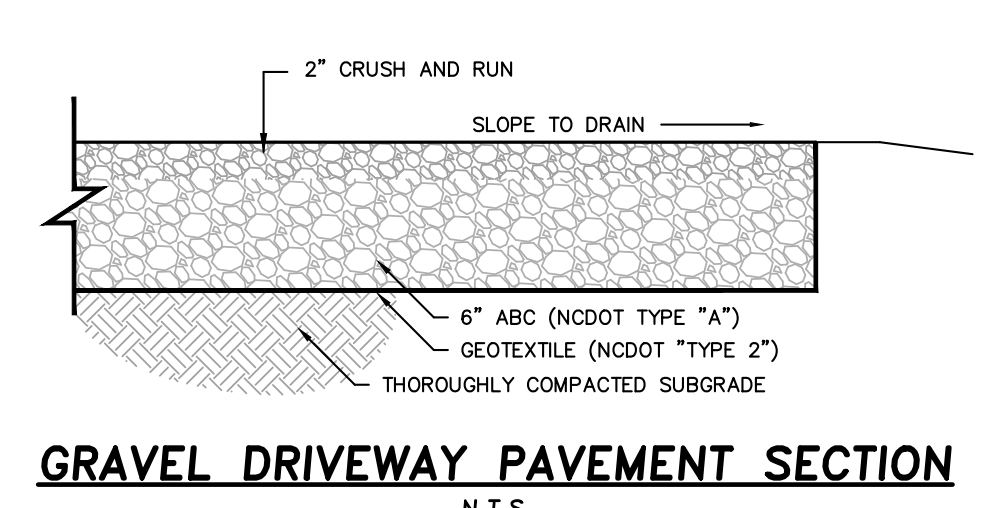

GRAVEL DRIVEWAY PAVEMENT SECTION
N.T.S.

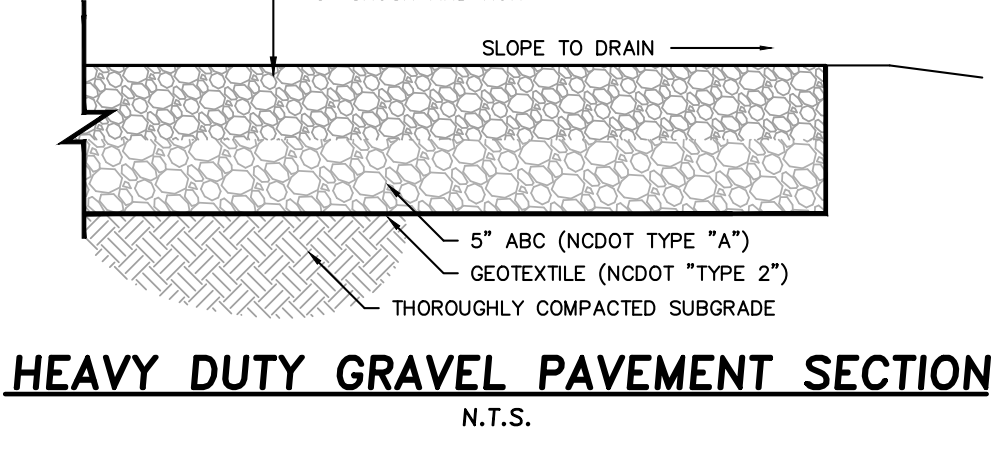

HEAVY DUTY GRAVEL PAVEMENT SECTION
N.T.S.

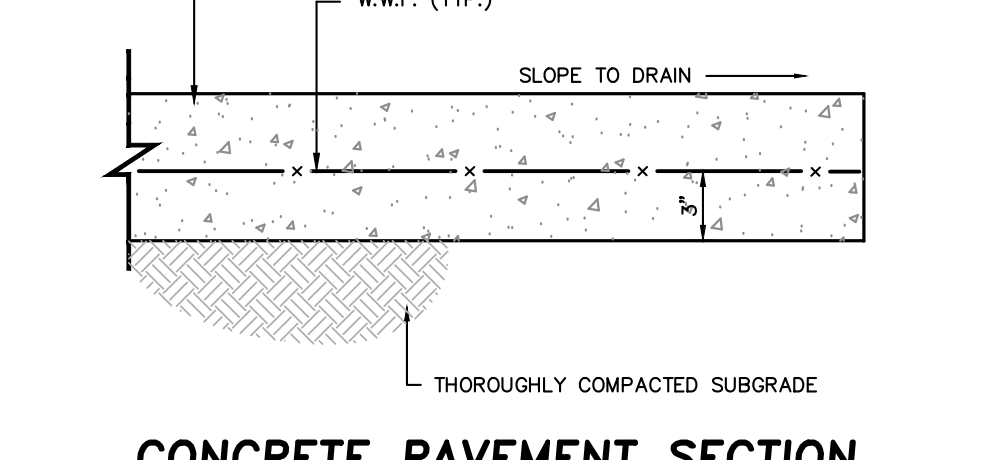

CONCRETE PAVEMENT SECTION
N.T.S.

- COMPACTION NOTES:**
- PROOF ROLL ALL NEW PAVED AREAS. NOTIFY OWNER AND ENGINEER OF ANY UNACCEPTABLE AREAS.
 - COMPACT BACKFILL AND SUBGRADE TO 95% OF THE MODIFIED PROCTOR MAXIMUM DRY DENSITY (ASTM D1557) ALL BACKFILL MATERIAL SHALL BE SELECT BACKFILL UNLESS OTHERWISE SPECIFIED BY THE ENGINEER.
 - SELECT FILL SHALL CONSIST OF SAND OR GRAVEL CONTAINING LESS THAN 20% BY WEIGHT OF FINES (SP, SM, SW, GP, GW) HAVING A LIQUID LIMIT LESS THAN 20 AND PLASTIC LIMIT LESS THAN 6, AND FREE OF RUBBLE, ORGANICS, CLAY, DEBRIS, AND OTHER UNSUITABLE MATERIAL.

COMPACTION NOTES
N.T.S.

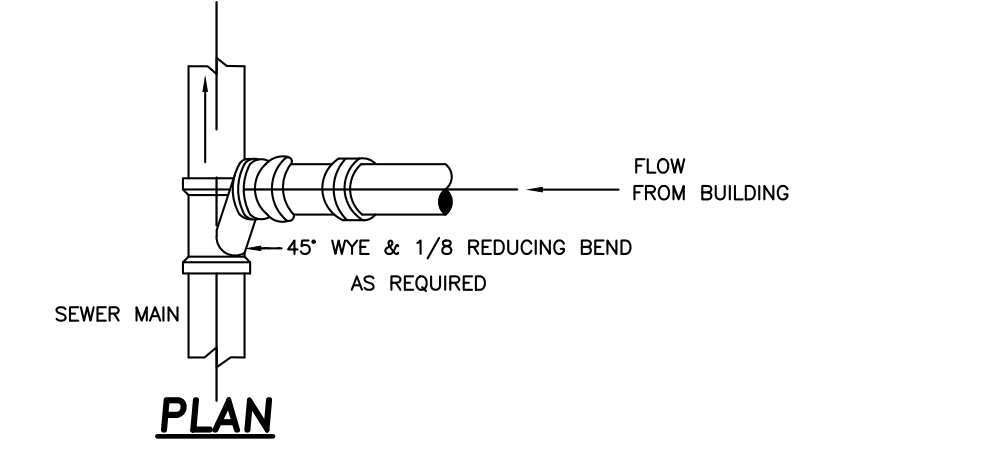

SERVICE CONNECTION
N.T.S.

PIPE SIZE	MIN. SLOPE
4"	1.00%
6"	.60%
8"	.40%
12"	.22%

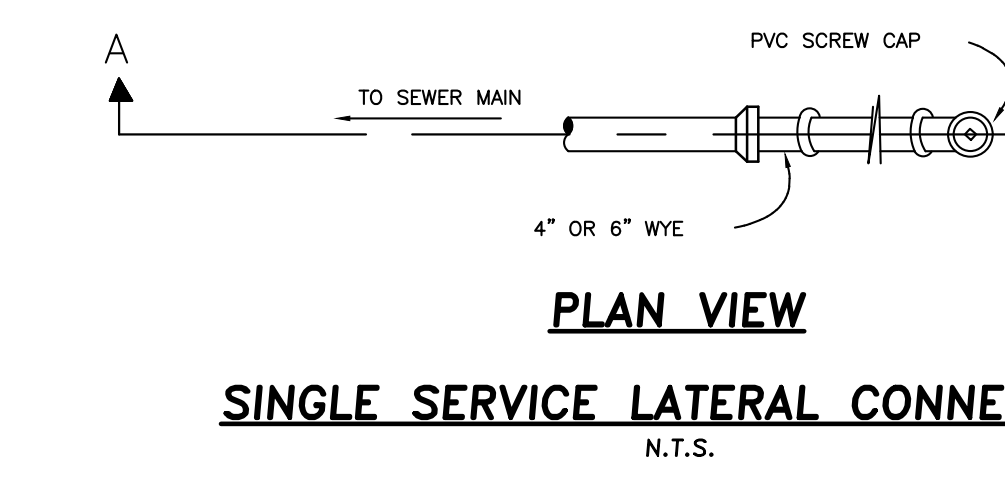
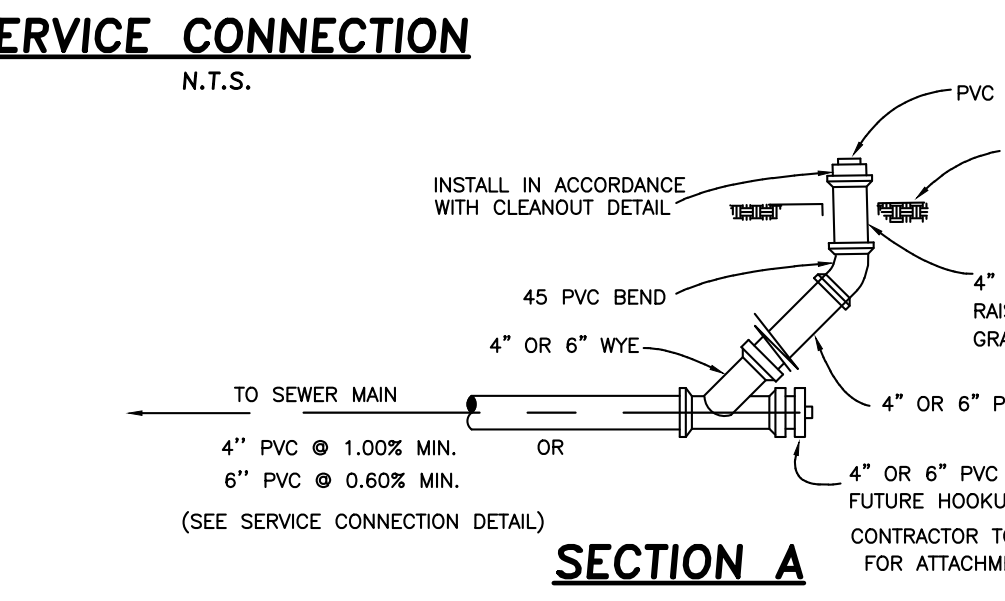

SINGLE SERVICE LATERAL CONNECTION
N.T.S.

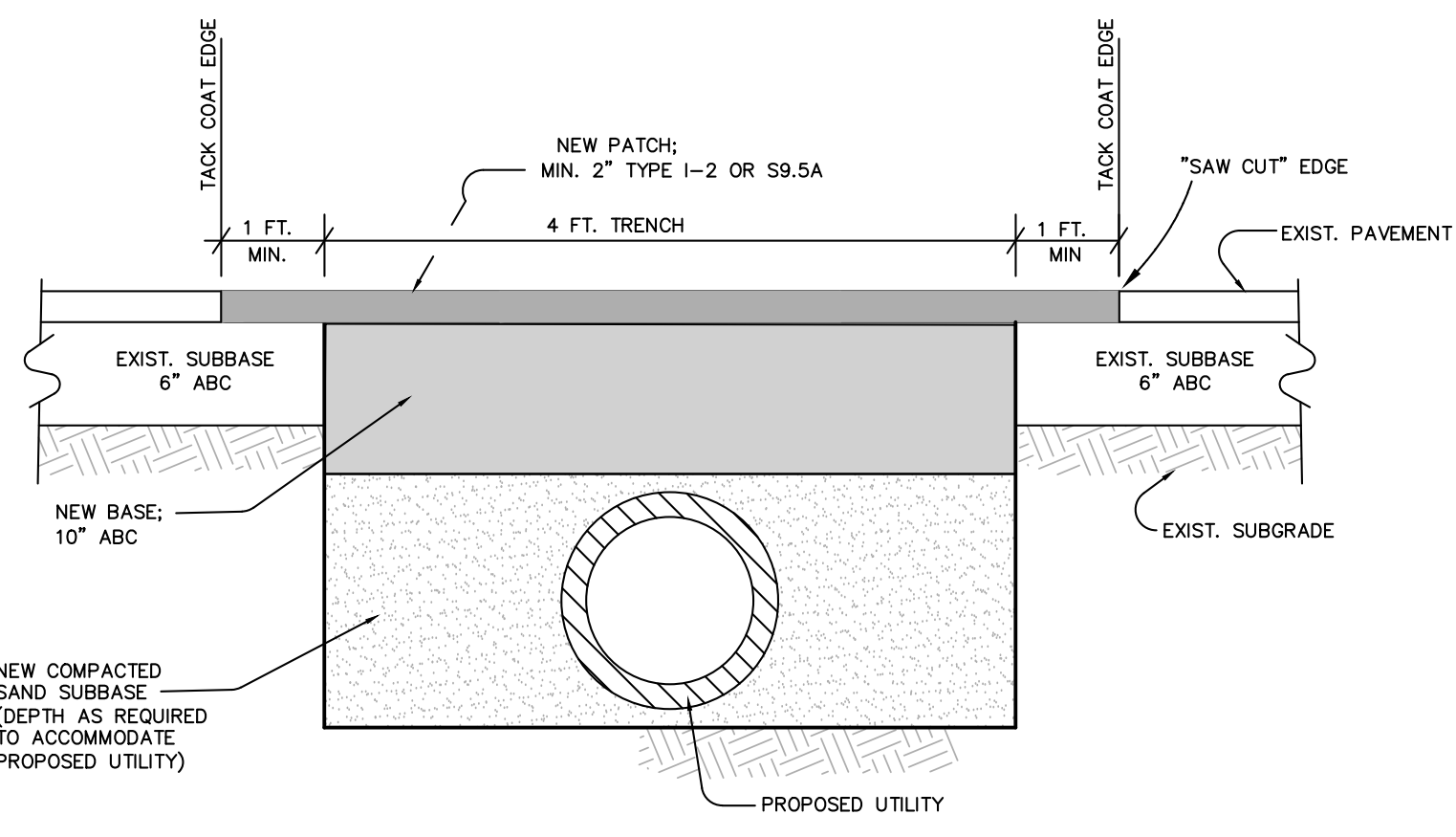

"SAW CUT" CONSTRUCTION/PATCH DETAIL
N.T.S.

NOTE: WHERE WATER MAIN IS UNDER PAVED AREAS, COMPACT BACKFILL IN 6" LAYERS TO 95% OF THE MAXIMUM DENSITY AS DETERMINED BY AASHTO METHOD T-99.

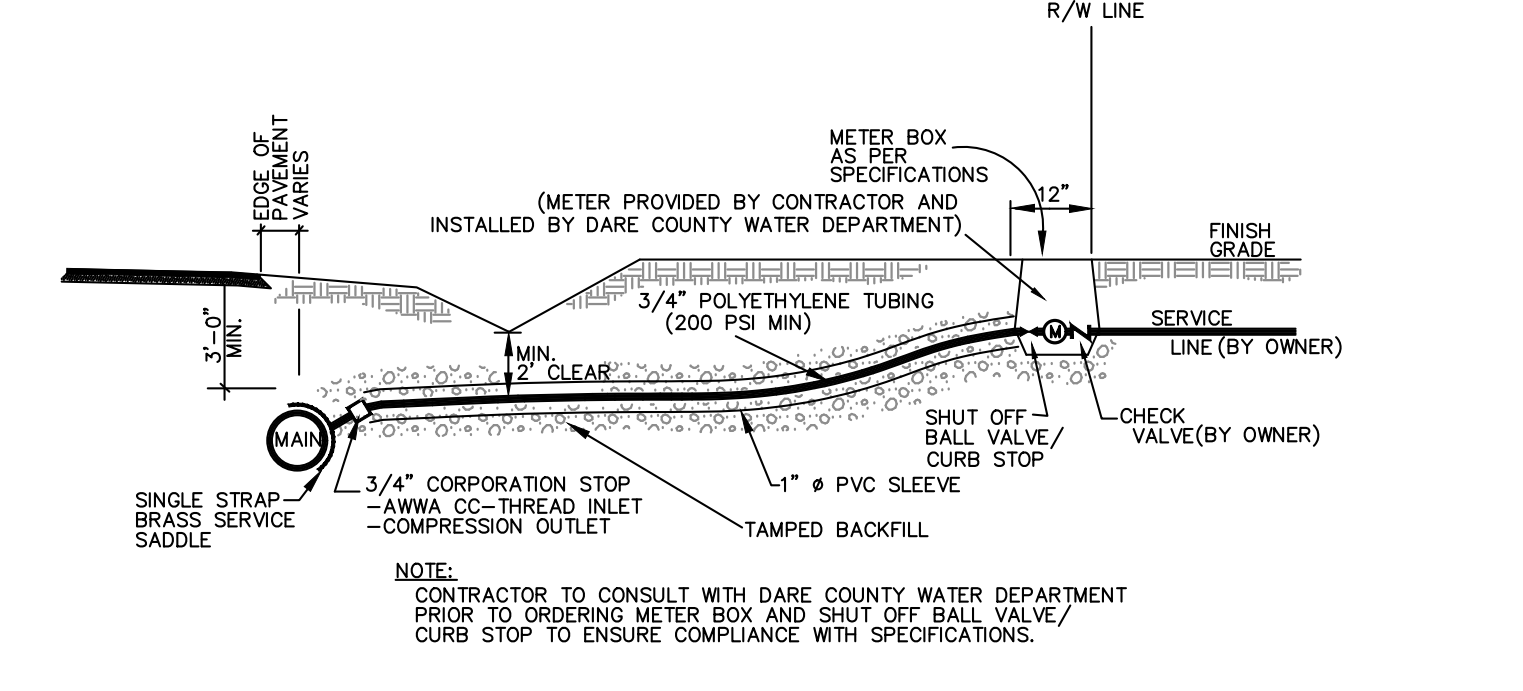

STANDARD 3/4" SERVICE LINE AND METER BOX INSTALLATION
N.T.S.

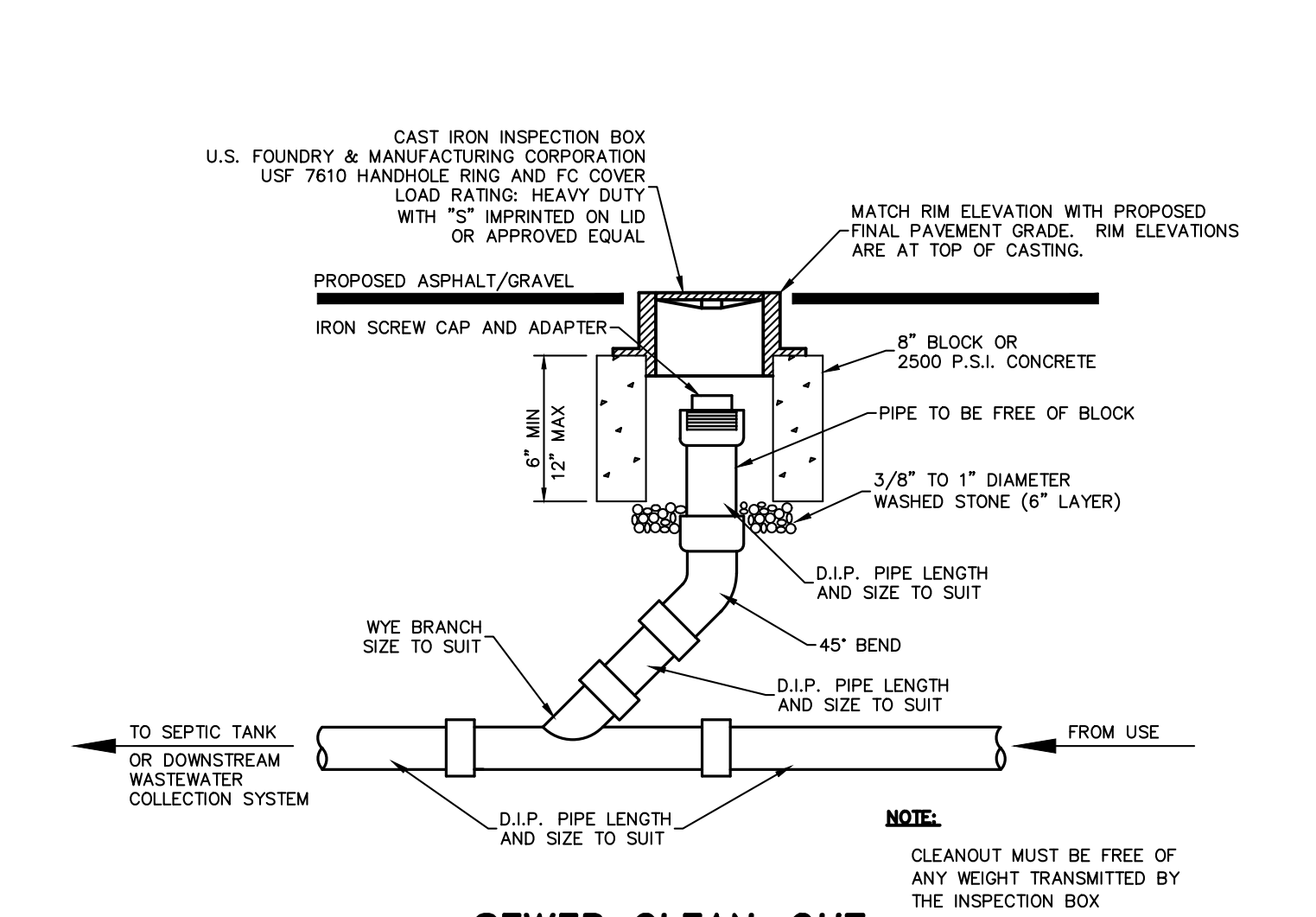

SEWER CLEAN-OUT WITHIN PAVEMENT
N.T.S.

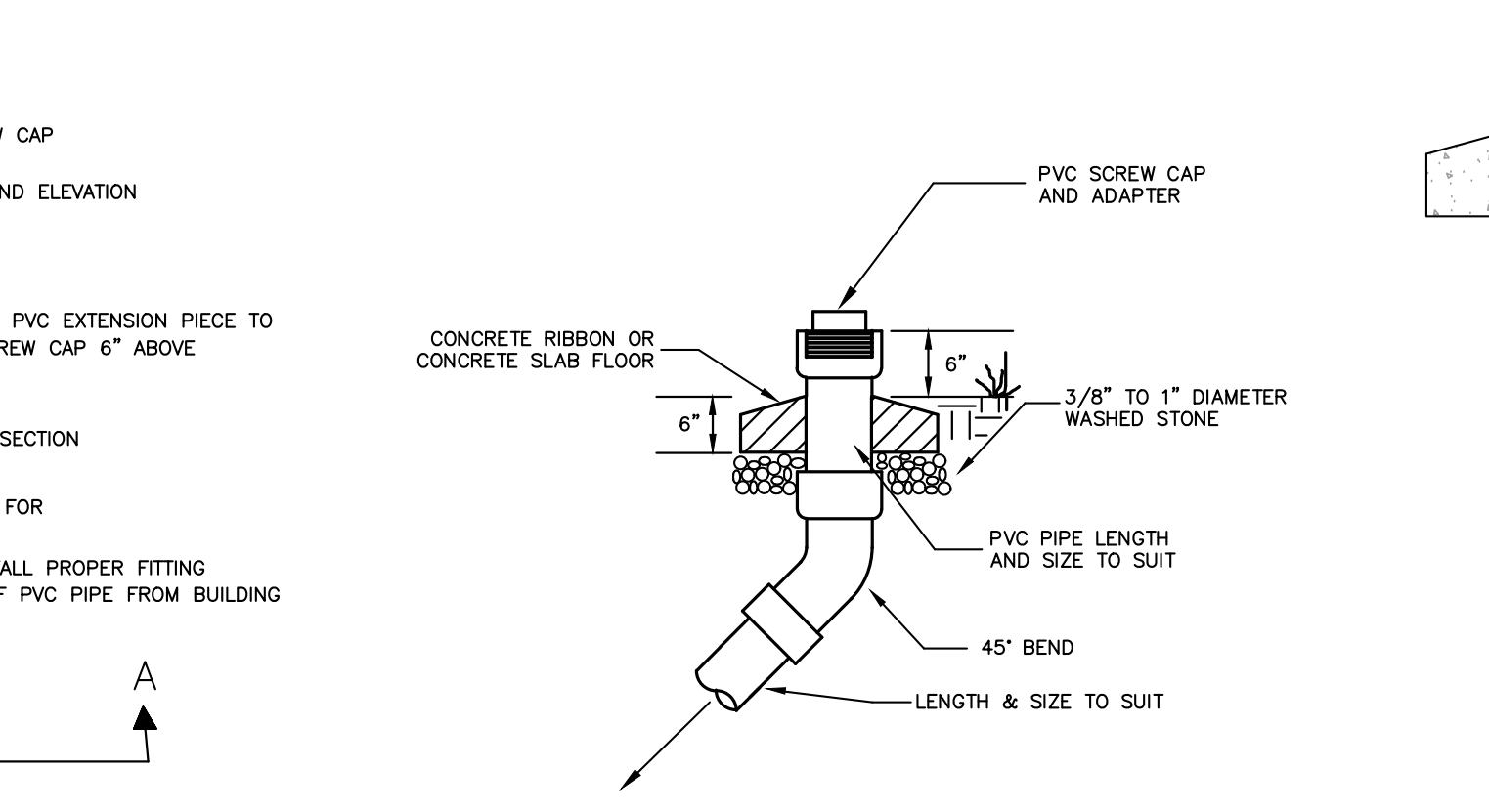

TYPICAL SEWER CLEAN-OUT
N.T.S.

PERMANENT VEGETATION

SEEDING DATES: APRIL 1 - AUGUST 31:

SEED MIXTURE	APPLICATION RATES/ACRE
REBEL II FESCUE	130 LBS.
COMMON BERMUDA "SAHARA" (HULLED)	215 LBS.

SEEDING DATES: SEPT. 1 - MARCH 31:

SEED MIXTURE	APPLICATION RATES/ACRE
REBEL II FESCUE	250 LBS.
COMMON BERMUDA "SAHARA" (UNHULLED)	215 LBS.

SOIL AMENDMENTS:
OBTAIN A SOIL TEST TO DETERMINE APPLICATION RATES AND FOLLOW RECOMMENDATIONS OF SOIL TESTS. WHEN A SOIL TEST IS NOT POSSIBLE, APPLY 3,000 LB/ACRE GROUND AGRICULTURAL LIMESTONE AND 1,000 LB/ACRE 10-10-10 STARTER FERTILIZER.

TEMPORARY VEGETATION

SEEDING DATES: AUG. 16 - APRIL 15:

SEED MIXTURE	APPLICATION RATES/ACRE
RYE GRAIN	120 LBS.

SEEDING DATES: APRIL 16 - AUG. 15:

SEED MIXTURE	APPLICATION RATES/ACRE
GERMAN MILLET	40 LBS.

MULCHING:
APPLY 4,000 LB/ACRE GRAIN STRAW OR EQUIVALENT COVER OF ANOTHER SUITABLE MULCH. ANCHOR STRAW BY TACKING WITH ASPHALT, NETTING, ROVING OR BY CRIMPING WITH A MULCH ANCHORING TOOL.

SEEDING SPECIFICATIONS

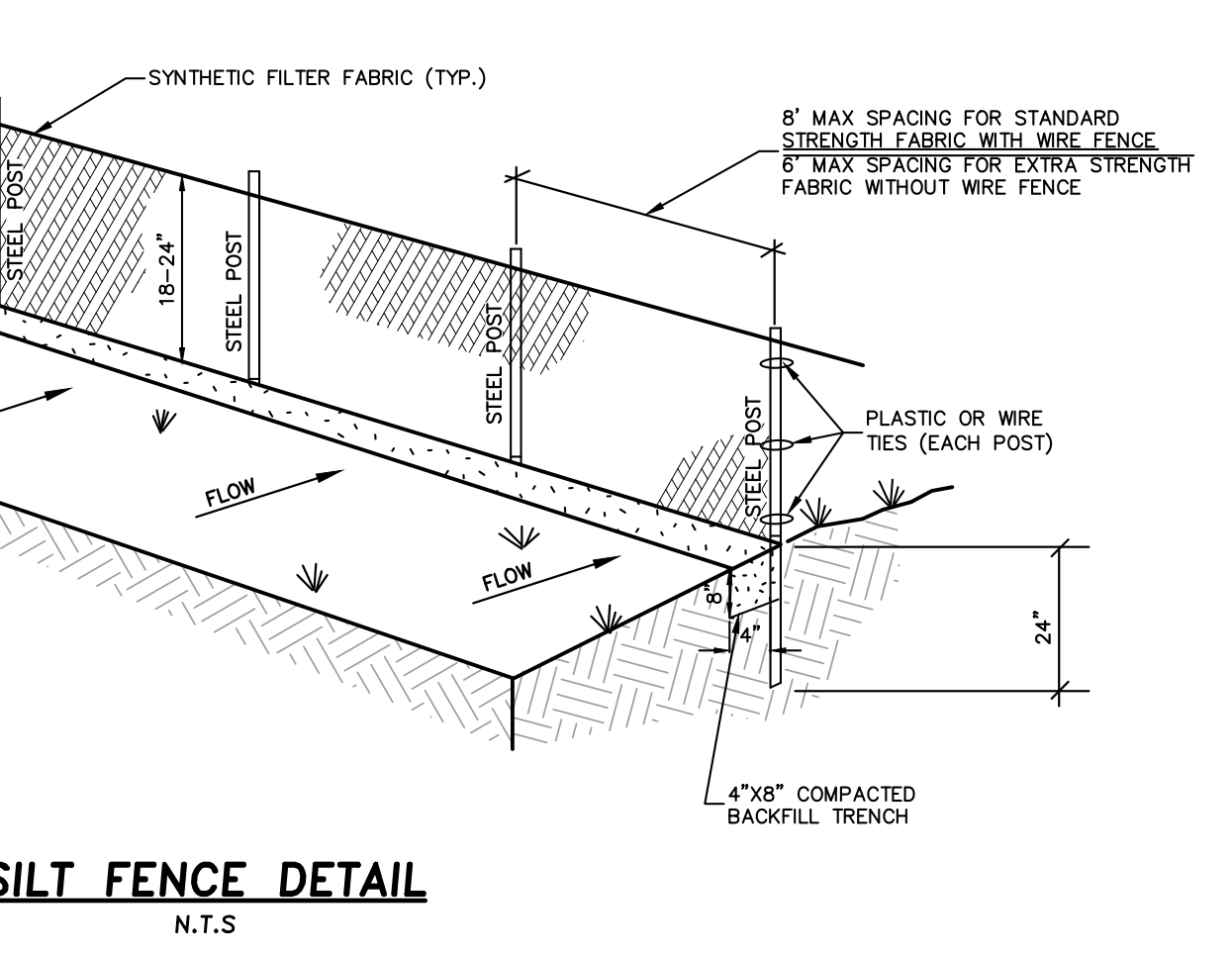

SILT FENCE DETAIL
N.T.S.

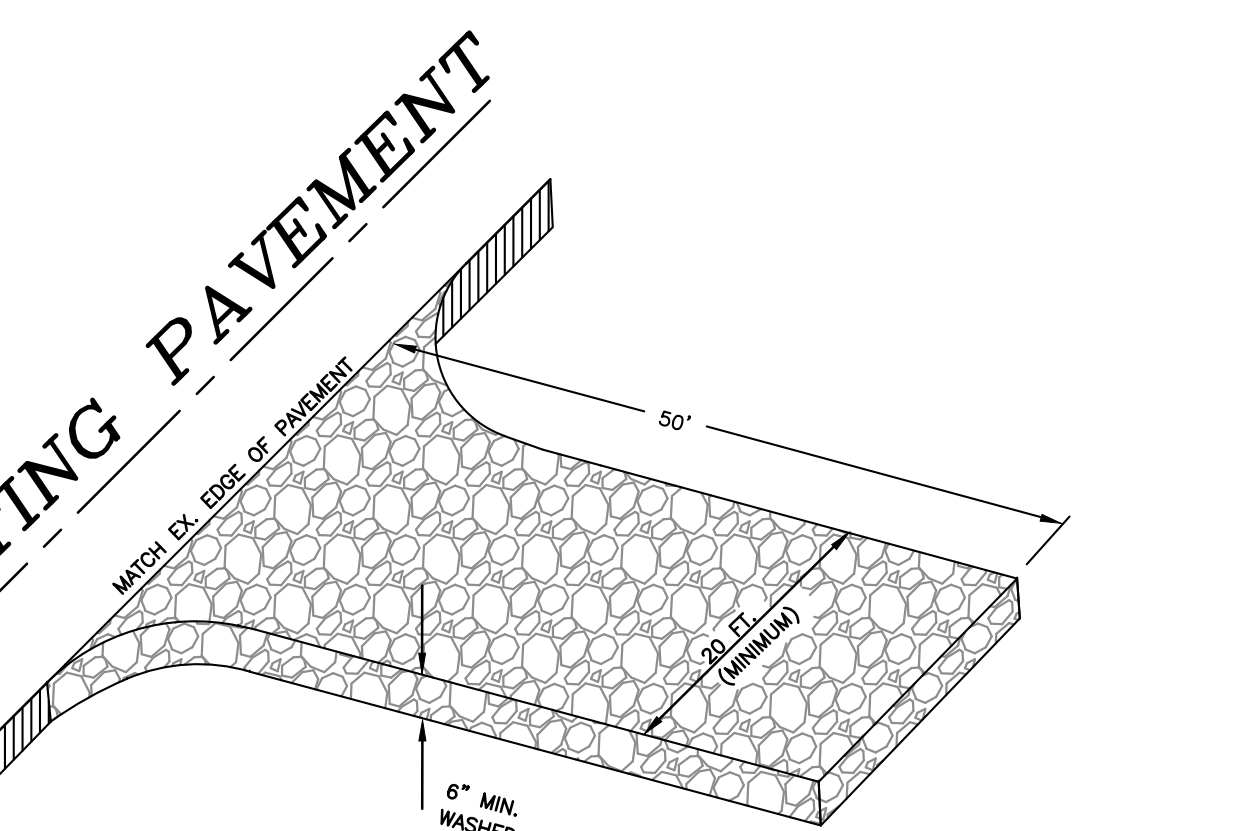

GRAVEL CONSTRUCTION ENTRANCE/EXIT DETAIL
N.T.S.

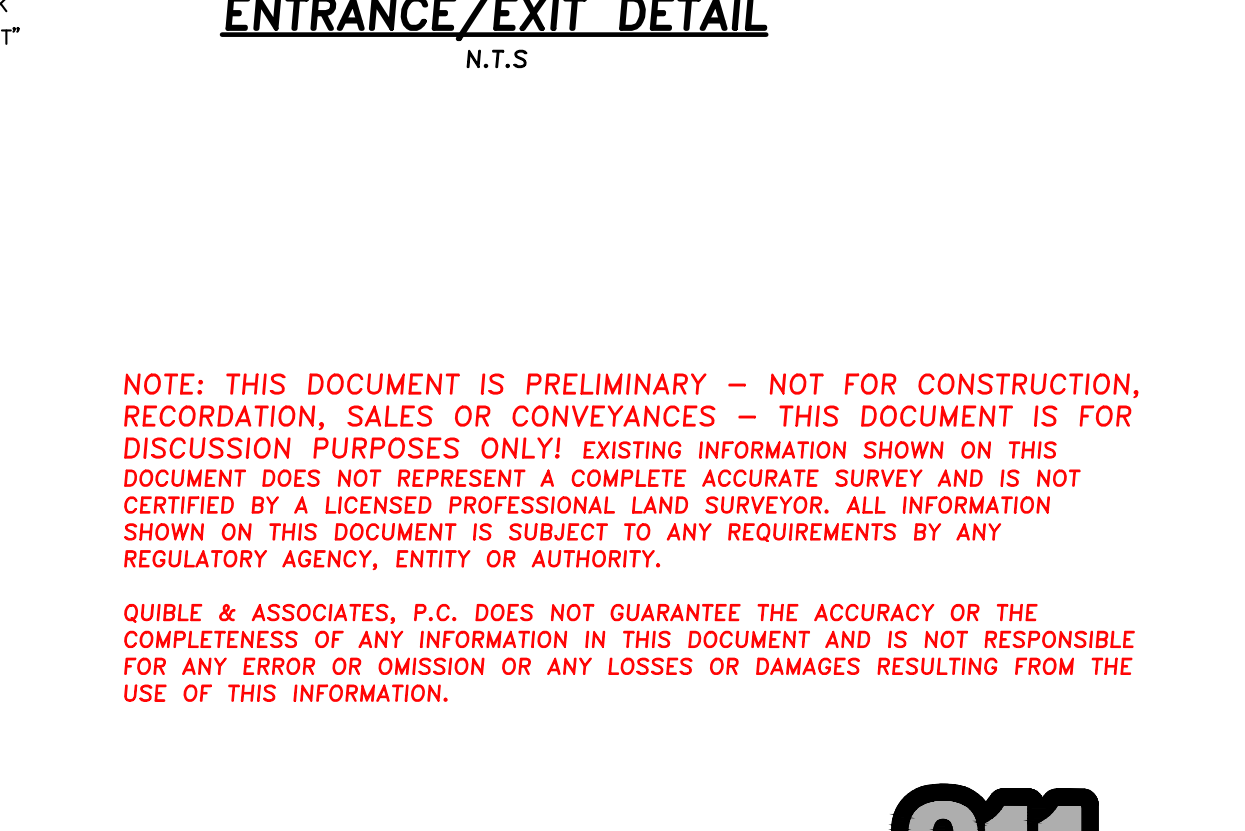

VALVE BOX DETAIL
N.T.S.

NOTE: THE DATA GIVEN ON THESE PLANS IS BELIEVED TO BE ACCURATE, BUT THE ACCURACY IS NOT GUARANTEED. THE CONTRACTOR IS RESPONSIBLE FOR VERIFYING ALL LEVELS, LOCATIONS, TYPES, AND DIMENSIONS OF THE EXISTING UTILITIES PRIOR TO CONSTRUCTION. IF A DISCREPANCY IS FOUND, WORK SHALL CEASE AND THE ENGINEER NOTIFIED. WORK MAY CONTINUE UPON ENGINEERS NOTICE TO PROCEED.



NC License# C-0208
SINCE 1959
Quible & Associates, P.C.
CONSTRUCTION SURVEYING
ENVIRONMENTAL SCIENCE
HYDROLOGICAL/SURVEYING NOT OFFERED IN BLACK MOUNTAIN, NORTH CAROLINA
8446 CAROLINA HWY.
CARRINGTON, NC 27513
Phone: (252) 981-1477
Fax: (252) 981-1446
www.quibleandassociates.com

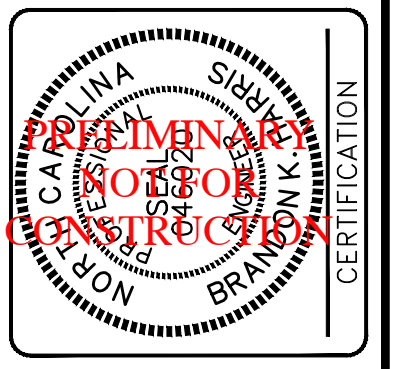

THIS DOCUMENT IS THE PROPERTY OF QUIBLE & ASSOCIATES, P.C. ANY ALTERATION OR REPRODUCTION IS PROHIBITED.
IF THIS DOCUMENT IS NOT SIGNED AND SEALED BY A LICENSED PROFESSIONAL ENGINEER, IT SHALL BE CONSIDERED PRELIMINARY. IT SHALL NOT BE USED FOR CONSTRUCTION OR ANY OTHER PURPOSES UNLESS OTHERWISE NOTED.

NO.	DATE	REVISIONS	REUSE SITE ACCESS PER PLANNING BOARD COMMENTS
1	01/16/19		

DETAILS
PARCEL A, HATTERAS ISLAND PLAZA
C. BRANTLEY TILLMAN, JR & R V OWENS III
NORTH CAROLINA
DARE COUNTY
KINNAKEET TOWNSHIP

COMMISSION NO. P17120
DESIGNED BY BKH
DRAWN BY JTM/JMH/BKH
CHECKED BY MWS
ISSUE DATE 12/10/18
SHEET NO. 2 OF 2 SHEETS



Conditional Use Permit No.5 --2018

Dare County Sections 22-25, 22-31.1, and 22-68.

Application of: Brantley Tillman and R.V Owens for OT Enterprises

On February 4, 2019 the Dare County Board of Commissioners considered the application of the Petitioner above named which application is on file with the Dare County Planning Department, and the Board finds as follows:

1. That the written application of Petitioner with attachments has been duly submitted to the Dare County Planning Board as required by Section 22 of the Dare County Code (hereinafter referred to as "Code");
2. That the application substantially complies with the requirements of the Code in that it requests uses permitted by conditional use permit under the Code, including residential structures in a group housing development;
3. The subject property is zoned C-2. This property is identified on the Dare County tax records as parcel 014822270 and located in the Avon tax district.
4. That the Dare County Planning Board recommended for approval the granting of this Conditional Use Permit as requested. The Planning Board made this recommendation on January 14, 2019.
5. That the Dare County Board of Commissioners is empowered under sections of the Code set out above to grant uses such as allowed herein and insofar as the conditional use is hereinafter allowed it will not adversely affect the public interest;
6. That the hereinafter described conditional use is deemed to be reasonable and is not in degradation of the intent of the ordinance.
7. That upon the evidence received, the testimony presented, and the submitted written record, there are sufficient facts to support the issuance of this Conditional Use Permit according to the terms and conditions below:

NOW, THEREFORE, under the provisions of the Code, the following conditional use is granted to OT Enterprises for a cluster home group development subject to such conditions as are hereinafter set out:

CONDITIONAL USE: a cluster home group development consisting of three residential structures as depicted on Appendix B included as part of this conditional use permit.

CONDITIONS:

1. The cluster home group development shall operate as prescribed in the definition set forth in Section 22-31.1 of the Dare County Zoning Ordinance. The structures shall be constructed as depicted on Appendix B and used not be occupied or rented on a short-term basis (less than 30 days) as defined in Section 22-2 of the Dare County Zoning Ordinance.
2. All structural improvements shall be located in the dwelling footprints as recorded on the final plat. The conditioned space of each structure shall not exceed 1200 square feet in area.
3. Parking improvements shall be in accordance to Section 22-56 of the Dare County Zoning Ordinance.
4. The structures shall be located on the parcel in conformance with the setbacks of Section 22-25 and Section 22-31.1 of the Zoning Ordinance.
5. A final site plan of the cluster home development depicting the footprint areas shall be recorded in the Register of Deeds. The cluster home sites may be transferred to individual owners with the remainder of the site dedicated as common area owners by a homeowners association or other similar entity. A copy of the signed conditional use permit shall be recorded with the final site plan.
6. Building permits for the structures shall be secured within 24 months from date of approval. The site improvements shall be constructed for compliance with the North Carolina fire codes, alternative means and methods, as depicted on Appendix B. The three structures shall be equipped with residential sprinkler systems. An as-built for the property shall be submitted to the Planning Department upon the completion of all three of the structures to confirm compliance with the terms of the Dare County Zoning Ordinance.
7. All other terms and provisions of the Dare County Zoning Ordinance shall remain in full force and effect except as herein specifically permitted otherwise;

This 4th day of February 2019

SEAL:

COUNTY OF DARE

By: _____
Robert L Woodard
Dare County Board of Commissioners

ATTEST:

By: _____
Gary Gross
Clerk to the Board

THIS PERMIT AND THE CONDITIONS HEREIN ARE ACCEPTED

By: _____
Brantley Tillman for OT Enterprises

APPROVED AS TO LEGAL FORM

By: _____
Robert L. Outten
County Attorney



Kendrick Albaugh -- Avon Zoning Map Amendment

Description

A zoning map amendment for the Avon zoning map has been submitted by Kendrick Albaugh to rezone a parcel currently zoned R2-A to a C-2 commercial designation. A staff report and supporting documentation are attached with the cover sheet.

Board Action Requested

Motion to schedule a public hearing – “I move to schedule a public hearing for Tuesday, February 19, 2019 at 5:30 p.m.

Item Presenter

Donna Creef, Planning Director

STAFF REPORT February 4, 2019 Board of Commissioners Meeting

FROM: Donna Creef, Planning Director

RE: Avon Zoning Map Amendment – Kendrick Albaugh
Request for a Public Hearing

A zoning map amendment application has been filed by Mr. Kendrick Albaugh for property located 40041 Brinkley Lane in Avon, NC. The property is currently zoned R-2A, residential. The structures on the property were constructed in 1985 and are used as storage warehouses. The commercial use of the property was not identified during the development of the Avon zoning map in 1992 and as a result the classification of R-2A was applied to the site. I have attached a copy of the Avon zoning map with the Albaugh property highlighted. The property is located in close proximity to properties zoned C-2 commercial. The property to the east of Mr. Albaugh's property is R-2A and is currently vacant. The property to the south of Albaugh's property is classified with R-2A to the rear of the tract and C-2 to the front portion. This split designation is consistent with the uses on the property (residential and restaurant). The properties to the north of Albaugh's property are residential.

During the development of zoning maps, it has been the County's practice to apply a zoning classification consistent with the use of the property at the time of map development. A review of the Avon zoning files from 1992 found no mention of commercial use of 40041 Brinkley Lane although the tax records indicate the date of construction of the buildings as 1985. It would appear the Albaugh property was incorrectly classified in 1992. Map adjustments have been made in the past when properties were incorrectly classified. Reclassification to C-2 has been requested by Mr. Albaugh based on the zoning classifications of surrounding properties. The C-2 district does not list storage warehouses as a permitted or conditional use. In order to make the property entirely conforming with a correct zoning classification, a text amendment to the C-2 district to add storage warehouses to the list of conditional use in the C-2 district was recommended by the Planning Board. The Planning Board's recommendation was to extend the C-2 classification to include the Albaugh property and the adjacent vacant property so the C-2 is contiguous. This recommendation was made at the January 14, 2019 Planning Board meeting.

In order to move forward on this recommendation, a public hearing on the matter is required. The requested action is to schedule a hearing for Tuesday, February 19, 2019 at 5:30 p.m.



ALBAUGH PROPERTY





This map is prepared from data used for the inventory of the real property for tax purposes. Primary information sources such as recorded deeds, plats, wills, and other primary public records should be consulted for verification of the information contained in this map.

40041 Brinkley LN
 Avon NC, 27915
 Parcel: 014720000
 Pin: 054905198340

Owners: Albaugh, Kenrick J

Building Value: \$70,700
 Land Value: \$50,300
 Misc Value: \$4,300
 Total Value: \$125,300

Tax District: Avon
 Subdivision: Subdivision - None
 Lot BLK-Sec: Lot: Blk: Sec:
 Property Use: Warehouse
 Building Type: Mini Warehouse
 Year Built: 1985





Update on the Bonner Bridge Replacement

Description

The Board of Commissioners will review community input that has been submitted online to the County regarding the naming of the Bonner Bridge replacement and discuss NCDOT's timetable for the opening of the new span over Oregon Inlet.

Board Action Requested

Discuss and take appropriate action

Item Presenter

Robert Outten, County Manager



Series 2019 Limited Obligation Bonds Reimbursement Resolution and Capital Project Ordinance

Description

Please see the attached Item Summary.

Board Action Requested

Adopt the Reimbursement Resolution and the Capital Project Ordinance.

Item Presenter

David Clawson, Finance Director

Item Summary: Series 2019 Limited Obligation Bonds Reimbursement Resolution and Capital Project Ordinance

The Series 2019 Limited Obligation Bonds (LOBs) are planned per the adopted 2019 CIP to finance COA new construction and renovations, Animal Shelter new construction, and Health & Human Services construction/renovation. On 1/22 the Board added the purchase of and renovations to 711/715 US Highway 64/264, Manteo. The projects and their estimates, which total \$12,009,200 without costs of issuance, are listed on Exhibit A to the Reimbursement Resolution.

The Reimbursement Resolution is needed due to an IRS requirement, since the bonds will be a tax exempt debt issuance. The Reimbursement Resolution declares the County's intent to reimburse itself from debt proceeds upon the debt closing, which will be September 2019 or later, dependent upon architectural and procurement schedules. The reimbursement allows the County to proceed with design, engineering, and other costs and to use the future debt proceeds as the revenue for the project budget.

The Capital Project Ordinance (CPO) makes object # and project # corrections and establishes a central budget for the LOBs (project #98726) by amending previously adopted CPOs for the 2018 CIP (9/18/2017), the 2019 CIP (8/6/2018), and the Manteo property (1/22/2019).

The CPO adds two additional amounts to the grand total, bringing the amount budgeted to date to \$1,390,000.

Based on experience with prior construction projects, staff recommends that \$20,000 be added to the preliminary Animal Shelter budget for Owner Costs which will include printing (plans, submittals, etc.), permits (other than NCDEQ), and miscellaneous owner costs (advertising, UPS, mail, etc.).

A total of \$1,000,000 is added for the Manteo property - \$712,500 for purchase and \$287,500 for renovations.

EXTRACTS FROM MINUTES OF THE BOARD OF COMMISSIONERS

A regular meeting of the Board of Commissioners of the County of Dare, North Carolina, was duly held on February 4, 2019 at 9:00 a.m. in the County Board of Commissioners’ Meeting Room, 954 Marshall C. Collins Drive, Manteo, North Carolina. Chairman Robert Woodard presiding.

The following members were present:

The following members were absent:

* * * * *

Commissioner _____ moved that the following resolution, copies of which having been made available to the Board of Commissioners, be adopted:

**RESOLUTION OF THE COUNTY OF DARE, NORTH CAROLINA
DECLARING THE INTENT OF THE COUNTY OF DARE, NORTH
CAROLINA TO REIMBURSE ITSELF FOR CAPITAL
EXPENDITURES FROM THE PROCEEDS OF CERTAIN TAX-
EXEMPT OBLIGATIONS**

WHEREAS, the Board of Commissioners of the County of Dare, North Carolina (“County”) has determined that it is in the best interests of County to proceed with the following projects: (1) construction of a new building for the College of the Albemarle, (2) renovation of existing facilities on the College of the Albemarle Russell Twiford campus, (3) construction and renovation of facilities for the Department of Health and Human Services, (4) construction of an animal shelter and (5) purchase of land and buildings contiguous to Manteo Elementary School and renovation of those facilities (collectively, the “Projects”);

WHEREAS, the County presently intends, at one time or from time to time, to finance all or a portion of the costs of the Projects with proceeds of tax-exempt obligations and reasonably expects to cause to be executed and delivered tax-exempt obligations (the “Obligations”) to finance, or to reimburse itself for, all or a portion of the costs of the Projects; and

WHEREAS, the County desires to proceed with some or all of the Projects and will incur and pay certain expenditures in connection with the Projects prior to the date of execution and delivery of the Obligations (the “Original Expenditures”), such Original Expenditures to be paid for originally from a source other than the proceeds of the Obligations, and the County intends, and reasonably expects, to be reimbursed for such Original Expenditures from a portion of the proceeds of the Obligations to be executed and delivered at a date occurring after the dates of such Original Expenditures;

NOW, THEREFORE, BE IT RESOLVED by the Board of Commissioners of the County of Dare, North Carolina as follows:

Section 1. ***Official Declaration of Intent.*** The County presently intends, and reasonably expects, to reimburse itself for the Original Expenditures incurred and paid by the County on or after the date occurring 60 days prior to the date of adoption of this Resolution from a portion of the proceeds of the Obligations. The County reasonably expects to execute and deliver the Obligations to finance all or a portion of the costs of the Projects and the maximum principal amount of Obligations expected to be executed and delivered by County to pay for all or a portion of the costs of the Projects is approximately \$12,000,000, a current estimate of which is further broken out for the Projects on Exhibit A to this Resolution.

Section 2. ***Compliance with Regulations.*** The County adopts this Resolution as a declaration of official intent under Section 1.150-2 of the Treasury Regulations promulgated under Section 103 of the Internal Revenue Code of 1986, as amended, to evidence the County's intent to reimburse itself for the Original Expenditures from proceeds of the Obligations.

Section 3. ***Itemization of Capital Expenditures.*** The Finance Director of the County, with advice from bond counsel, is hereby authorized, directed and designated to act on behalf of the County in determining and itemizing all of the Original Expenditures incurred and paid by the County in connection with the Projects during the period commencing on the date occurring 60 days prior to the date of adoption of this Resolution and ending on the date of execution and delivery of the Obligations.

Section 4. ***Effective Date.*** This Resolution shall become effective immediately upon the date of its adoption.

EXHIBIT A

PRELIMINARY PROJECT AMOUNTS

<u>College of the Albemarle</u>		
New construction	\$7,500,000	
Renovations at Russell Twiford campus	<u>\$1,000,000</u>	
Total		\$8,500,000
Less bonds funds from State of NC		<u>(\$1,500,000)</u>
Net amount for debt		\$7,000,000
<u>Dare County Department of Health & Human Services</u>		
New construction – consolidation of buildings		\$2,009,200
<u>Dare County Animal Shelter</u>		
New construction		\$2,000,000
<u>Property and Buildings at 711 and 715 N. Highway 64/264, Manteo</u>		
Purchase and land and buildings	\$712,500	
Renovation costs	<u>\$287,500</u>	
Total amount for debt		<u>\$1,000,000</u>
Preliminary grand total for debt		\$12,009,200

STATE OF NORTH CAROLINA)
)
COUNTY OF DARE) SS:

I, Gary L. Gross, Clerk to the Board of Commissioners of the County of Dare, North Carolina, *DO HEREBY CERTIFY*, as follows:

1. A regular meeting of the Board of Commissioners of the County of Dare, a political subdivision of the State of North Carolina, was duly held on February 4, 2019, proper notice of such meeting having been given as required by North Carolina statute, and minutes of said meeting have been duly recorded in the Minute Book kept by me in accordance with law for the purpose of recording the minutes of said Board of Commissioners.

2. I have compared the attached extract with said minutes so recorded and said extract is a true copy of said minutes and of the whole thereof insofar as said minutes relate to matters referred to in said extract.

3. Said minutes correctly state the time when said meeting was convened and the place where such meeting was held and the members of said Board who attended said meeting.

IN WITNESS WHEREOF, I have hereunto set my hand and have hereunto affixed the corporate seal of said County, this 4th day of February, 2019.

(SEAL)

GARY L. GROSS
Clerk to the Board of Commissioners
County of Dare, North Carolina

**County of Dare, North Carolina
Capital Project Ordinance
for
Series 2019 LOBs**

BE IT ORDAINED as authorized by the Board of Commissioners of the County of Dare, North Carolina that, pursuant to Section 13.2 of Chapter 159 of the General Statutes of North Carolina, the following capital project ordinance is hereby adopted for the planned Series 2019 Limited Obligation Bonds:

Section 1 This ordinance is to amend the budget for the College of the Albemarle and the Animal Shelter projects approved with the FY 2019 CIP, and to establish a budget for the property purchase and related renovations at 711 and 715 North Highway 64/264, Manteo, NC, approved by the Board on January 22, 2019. This ordinance also amends the related line items in capital project ordinances adopted September 18, 2017, August 6, 2018, and January 22, 2019, and adds owner costs for the Animal Shelter project.

Section 2 The following budget shall be conducted within the Capital Projects Fund (fund #61).

Section 3 The following amounts are changed as indicated for appropriations for the projects:

COA – Architectural	615576-710900-60332	\$75,000	increase
COA – FY2019 CIP Project	615576-737436-60332	(\$75,000)	decrease
COA – Architectural	615576-710900-60332	\$35,000	increase
COA – FY2018 CIP Project	615576-710900-60332	(\$35,000)	decrease
Animal Shelter - Architectural	615550-710900-60339	\$230,980	increase
Animal Shelter–Construction Testing Owner	615550-710911-60339	\$14,800	increase
Animal Shelter-Arch Additional Services	615550-710912-60339	\$14,760	increase
Animal Shelter – Owner Costs	615550-737002-60339	\$20,000	addition
Animal Shelter – FY2019 CIP Project	615550-737436-60339	(\$260,540)	decrease
Manteo Property–Land&Bldng Purchase	615490-737101-60340	\$712,500	increase
Manteo Property – Renovations	615490-737006-60340	\$287,500	increase

Section 4 The following revenues are anticipated to be available to complete the projects as changed or added below:

Debt Proceeds S2019 LOBs COA	613090-470318-98726	\$75,000	increase
Debt Proceeds S2019 LOBs COA	613090-470318-60332	(\$75,000)	decrease
Debt Proceeds S2019 LOBs AS	613090-470318-98726	\$280,540	increase
Debt Proceeds S2019 LOBs AS	613090-470318-60339	(\$260,540)	decrease
Debt Proceeds S2019 LOBs Property	613090-470318-98726	\$1,000,000	increase

Section 5 After this amendment, the following amounts will have been budgeted for the S2019 LOBs to date:

COA	\$110,000	
Animal Shelter	\$280,540	
Manteo property & renovations	\$1,000,000	
Total		\$1,390,000

Section 5 The Finance Officer is directed to report the financial status of the project as a part of the normal ongoing financial reporting process.

Section 6 Copies of this capital project ordinance shall be furnished to the Budget Officer, the Finance Officer and to the Clerk to the Board of Commissioners.

Adopted this 4th day of February, 2019.

Chairman, Board of Commissioners

[SEAL]

Gary L. Gross, Clerk to the Board of Commissioners



Consent Agenda

Description

1. Approval of Minutes (01.22.19)
2. Public Health Division - Purchase the Shingles Vaccine (Shingrix)
3. Sanitation - Budget Amendment to Increase Container Purchases Line Item
4. Water Dept - NCDOT Right of Way Encroachment Agreement, 1182 Duck Road
5. Water Dept - NCDOT Right of Way Encroachment Agreement, Barley Lane, Frisco
6. Water Department Budget Amendment
7. Advertise 2018 Tax Year Liens

Board Action Requested

Approval

Item Presenter

County Manager, Robert Outten



Approval of Minutes

Description

The Board of Commissioners will review and approve their previous Minutes, which follow this page.

Board Action Requested

Approve Previous Minutes

Item Presenter

County Manager, Robert Outten



County of Dare

P.O. Box 1000 | Manteo, NC 27954

MINUTES

DARE COUNTY BOARD OF COMMISSIONERS MEETING

Dare County Administration Building, Manteo, NC

5:00 p.m., Tuesday, January 22, 2019

Commissioners present: Chairman Robert Woodard, Vice Chairman Wally Overman
Rob Ross, Steve House, Jim Tobin, Ervin Bateman

Commissioners absent: Danny Couch

Others present: County Manager/Attorney, Robert Outten
Deputy County Manager/Finance Director, David Clawson
Public Information Officer, Dorothy Hester
Clerk to the Board, Gary Lee Gross

A full and complete account of the entire Board of Commissioners meeting is archived on a video that is available for viewing on the Dare County website www.darenc.com.

At 5:03 p.m. Chairman Woodard called to order the regularly scheduled meeting with appropriate prior public notice having been given. He invited Wayne Barry to share a prayer, and then he led the Pledge of Allegiance to the flag.

Chairman Woodard reported that Commissioner Couch had an excused absence in order for him to attend an important community meeting on Hatteras Island.

Note – some agenda items were handled out of sequential order to accommodate the time specific Public Hearings scheduled for 5:30 p.m.

ITEM 1 – OPENING REMARKS – CHAIRMAN’S UPDATE

Following is a brief outline of the items mentioned by Chairman Woodard during his opening remarks, which can be viewed in their entirety in a video on the Dare County website –

- Reported on a Board of Education meeting where he shared his COA presentation.
- Gave a briefing on his participation at the NCACC 2019 Legislative Goals Conference.
- Thanked the Lewis family for hosting the recent Dr. Martin Luther King event at the Dare County Center where he was honored to be the guest speaker.
- Thanked the Chamber of Commerce for their assistance with the recent “State of the County” event where a sold-out crowd gathered at Captain George’s restaurant.
- Asked everyone to keep Health and Human Services Director Sheila Davies in their thoughts and prayers as she recovers from knee surgery.

ITEM 2 – PUBLIC COMMENTS

At 5:09 p.m. the Manager outlined the procedure for making public comments in Manteo and via the video link to the Fessenden Center Annex in Buxton. Following is a summary of all citizen remarks, which can be viewed in their entirety in a video on the County website –

The following comments were made in Manteo –

1. James Fletcher asked that the Board make a request to the Cape Hatteras National Seashore that they undertake a survey of property at the southern portion of Bodie Island. He cited ownership issues and condemnation proceedings that he detailed in a packet of written material he presented to the County Manager. He expressed hope that resolving the issues he identified could ultimately help stabilize Oregon Inlet.

The following comments were made in Buxton –

2. Wanda Magness explained the need for golf carts to be able to safely cross Highway 12 in Buxton. She called for a lighted crossway on Highway 12, which she said would help hotel operators be able to take their guests back and forth to the beach.

The County Manager closed Public Comments at 5:17 p.m.

At the end of Public Comments, Mr. Outten asked Allen Moran, Dare County's representative on the North Carolina Board of Transportation, to give an update on NCDOT's plans for removal of the Bonner Bridge when the new span is completed. Mr. Moran described the demolition process, which he said will be done simultaneously in two parts to help clear the portion that impacts marine navigation as quickly as possible. He also reported on the status of the Record of Decision for the Mid-Currituck Bridge. Mr. Moran advised Commissioners that Moffatt & Nichol is still working on the stormwater survey of Roanoke Island and said their report is delayed due to adjustments that had to be made to the project's scope of work. He said the report is expected in approximately 40 days.

ITEM 3 – TOURISM BOARD RESTRICTED FUND EXPENDITURE REQUEST

Lee Nettles, Executive Director of the Outer Banks Visitors Bureau, presented a Long Term Restricted Fund spending request in the amount of \$50,000 for a site feasibility and economic impact study for the Soundside Event Site in Nags Head. He gave background information about the venue and explained that the study will serve an important role in updating the vision for site and determining the best use of the property.

MOTION

Commissioners Overman and Bateman motioned to approve the spending request.

Commissioner House seconded the motion.

VOTE: AYES unanimous

ITEM 4 – REPORT FROM THE NORTH CAROLINA COASTAL FEDERATION

Erin Fleckenstein, Coastal Scientist and Northeast Manager for the NC Coastal Federation, briefed Commissioners on the group’s mission to protect our coastal water quality and natural resources. She outlined the Federation’s goals for 2019-2021 and described ways for people to get involved. A video was shown highlighting a living shoreline project in Kitty Hawk and Ms. Fleckenstein answered Commissioner questions about marine debris pickup. Chairman Woodard and the Board were commended for their leadership in opposing offshore drilling.

ITEM 5 – ARCHITECTURAL CONTRACT – DESIGN OF NEW ANIMAL SHELTER (Att. #1)

Dustin Peele, Dare County Purchasing Agent, presented a proposed contract with Waller, Todd & Sadler to provide architectural and design services for the new Dare County Animal Shelter. Commissioners were asked to approve the contract and a Capital Project Ordinance amending the amount budgeted for the Animal Shelter in the FY2019 Capital Improvements Plan. The contract lists a total basic fee of \$230,980 with a schedule of additional services that are available for an added \$29,560. Along with the County Manager, Mr. Peele and Architect Dan Costello answered questions from the Board. They clarified the scope of work and fees for the additional services and explained that they are available to the County on an optional basis, if needed. Mr. Outten added that the County has done its due diligence and noted that animal shelters have special design needs that make it challenging to compare architectural fees as a percentage of construction costs.

MOTION

Vice Chairman Overman motioned to approve the contract with Waller, Todd & Sadler and approve the Capital Project Ordinance.

Commissioner Ross seconded the motion.

VOTE: AYES unanimous

(Att. #2)

ITEM 6-1 – PUBLIC HEARING – GOLF CARTS: MARTIN’S POINT & MANNS HARBOR

At 5:53 p.m. the Board held a Public Hearing to receive input concerning this agenda item. The Manager outlined the procedure for making public comments in Manteo and via the video link to the Fessenden Center Annex in Buxton. Following is a summary of all citizen remarks, which can be viewed in their entirety in a video on the County website –

The following comments were made in Manteo –

1. Joe Staten, President of the Martin’s Point Homeowners Association said his group supports having golf carts in their community and asked the Board to approve them.

There were no comments made in Buxton –

The County Manager closed the Public Hearing at 5:55 p.m.

MOTION

Vice Chairman Overman motioned to adopt the proposed amendments to Chapter 100 of the Dare County Code of Ordinances to allow the operation of golf carts in the residential sections of the Martin’s Point subdivision and in the village of Manns Harbor.

Commissioner House and Commissioner Tobin seconded the motion.

VOTE: AYES unanimous

ITEM 6-2 – PUBLIC HEARING – COMMERCIAL SERVICES (CS) ZONING AMENDMENTS

At 5:56 p.m. the Board held a Public Hearing to receive input concerning this agenda item. The Manager outlined the procedure for making public comments in Manteo and via the video link to the Fessenden Center Annex in Buxton. No one responded to the invitation to address the Board on this issue. The Manager closed the Public Hearing at 5:56 p.m.

MOTION

Commissioner Ross motioned to adopt the CS amendments as recommended by the Planning Board with the finding that these amendments are consistent with the Dare County Land Use Plan as set forth in the finding of consistency statement.

Commissioner Tobin seconded the motion.

VOTE: AYES unanimous

ITEM 7 – CONSENT AGENDA

The Manager announced the items as they were visually displayed in the meeting room.

MOTION

Commissioner House motioned to approve the Consent Agenda:

- 1) Approval of Minutes (01.07.19) **(Att. #3)**
- 2) Public Health Division – Maternal and Child Health Mini Grant
- 3) Public Health Division – NC Community Foundation Grant
- 4) Fire Department/Rescue Squad Contract and Agreements
- 5) Tax Collector's Report

Commissioner Bateman seconded the motion.

VOTE: AYES unanimous

ITEM 8 – COMMISSIONERS' BUSINESS & MANAGER'S/ATTORNEY'S BUSINESS

Commissioners and the County Manager frequently make extensive remarks, which can be viewed in their entirety in a video on the Dare County website. Following is a brief summary outline of the items mentioned by Commissioners during this segment –

Commissioner House

- Reported on a recent North Carolina Fisheries Association meeting that was conducted in Dare County, which he described as a good meeting.

Vice Chairman Overman

- Advised that work is still in progress on having a Recovery Court for Dare County
- Commended Chairman Woodard for the interesting way he imparted information at the recent "State of the County" presentation.
- Reported on a recent meeting he attended to address education related housing issues, which could benefit the Coastal Studies Institute, the College of the Albemarle, and the Dare County School System.

Commissioner Bateman

- Noted that Chairman Woodard gave a very inspiring message at the recent event to celebrate the life of Dr. Martin Luther King, Jr.
- Mentioned that he was glad to attend the NC Fisheries Association meeting that was recently held in Dare County.

Commissioner Tobin

- Commented that the “State of the County” event was fantastic and expressed how impressed he was by Fathom Daniels, the high school student who is participating in the Dual Enrollment program available through the Dare County School System.
- Reported that the Oregon Inlet Task Force Subcommittee has been working to finalize contracts related to Dare County’s acquisition of a dredge vessel.

Commissioner Ross

- Echoed positive comments that were made about the recent “State of the County” event.
- Advised that Melody Wilkins has been hired as the new Executive Director of the Albemarle Commission. He noted that the recent election of officers for the organization resulted in him being named Vice Chair. He also provided an update on the Albemarle Commission audit. Commissioner Ross added that the group’s organizational documents are being redone to address some minor discrepancies that exist between their Charter and their Bylaws. He said there will be no substantive changes in the revision, which will be presented to the Dare County Board of Commissioners in the future for approval.
- Provided details about a March 5th workshop with Teepa Snow that will address dementia and an Economic Development Summit planned for February 21.
- Said that he and Vice Chairman Overman will be participating in a webinar designed to help them as members of the Trillium Health Resources Board to keep up with changes.

Chairman Woodard

- Asked the Board to approve the following Commissioner Board/Committee assignments –
 - Audit Committee
 - Rob Ross, currently on the Committee, to replace Jack Shea as Chairman.
 - Ervin Bateman to then join Rob Ross as a member of the Audit Committee.
 - Board of Education - 5-on-5 Committee
 - Rob Ross to replace Jack Shea.
 - Albemarle RPO (Rural Planning Organization)
 - Wally Overman, the current Alternate, to replace Jack Shea as Commissioner Rep.
 - Danny Couch to become the new “Alternate” to the RPO.
 - Library Board – Dare
 - Ervin Bateman to replace Rob Ross.
 - Parks & Recreation Liaison
 - Ervin Bateman to replace Danny Couch.
 - Health & Human Services Board
 - Ervin Bateman to replace Bob Woodard.
 - Transportation Advisory Board
 - Jim Tobin to replace Jack Shea.

- Albemarle Regional Solid Waste Management Authority
 - Ervin Bateman to replace Jack Shea.

MOTION

Commissioner Tobin motioned to approve all the Chairman's requested appointments. Commissioner Ross seconded the motion.

VOTE: AYES unanimous

MANAGER'S/ATTORNEY'S BUSINESS

1. The County Manager explained that the Water Department has sent letters to Leslie Lane property owners on Hatteras Island concerning a possible water line extension. He summarized the responses that were received and reported that 8 property owners are in favor of the project with funding by a water assessment & 2 said they favor the project, but do not want an assessment. Chairman Woodard said he was inclined to address it by holding a Public Hearing. Mr. Outten indicated that the Water Dept. will send letters to the Leslie Lane property owners advising them of the Public Hearing.

MOTION

Chairman Woodard motioned to conduct a Public Hearing at 5:30 p.m., Tuesday, February 19.

Commissioner House seconded the motion.

VOTE: AYES unanimous

2. Mr. Outten informed the Board that the State has approved the grant for the Shallow Draft Inlet Fund for ongoing work at the Hatteras Island South Ferry Channel. He asked the Board to authorize him to sign the grant request so the project can move forward as planned.

MOTION

Vice Chairman Overman motioned to approve the request as presented.

Commissioner House seconded the motion.

VOTE: AYES unanimous

3. The Manager asked for a Closed Session pursuant to NCGS 143-318.11(a)(5) to instruct the County staff, or negotiating agents, concerning the position to be taken by or on behalf of the County in negotiating the price and other material terms of a contract, or proposed contract, for the acquisition of real property by purchase, option, exchange, or lease in the matter of the Old Kellogg Supply Building in Manteo. And, pursuant to NCGS 143-318.11(a)(3) to consult with the County Attorney in order to preserve the attorney-client privilege; and to approve minutes of the last Closed Session.

MOTION

Commissioner House motioned to go into Closed Session pursuant to the provisions of the North Carolina General Statutes cited by the County Manager.

Vice Chairman Overman seconded the motion.

VOTE: AYES unanimous

At 6:31 p.m., the Commissioners exited the room to meet in Closed Session. They reconvened at 6:57 p.m. and Mr. Outten reported that during the Closed Session the Board approved previous Closed Session Minutes, consulted with the County Attorney, and discussed the purchase of the Old Kellogg Supply Building. He outlined an offer to purchase the property at \$900,000 with the seller giving back to the County \$187,500 resulting in a net cost to the County of \$712,500. He explained that money for the purchase would come out of the Capital Improvements Plan. He added that the County has a 90 day due diligence period with settlement to occur within 120 days. The Board was asked to go into Open Session to approve the purchase as outlined by the County Manager and authorize him to execute all necessary documents.

MOTION

Commissioner Tobin motioned to approve the purchase as outlined by the Manager. Commissioner House seconded the motion.

VOTE: AYES unanimous Note: Commissioner Bateman had to leave the meeting at 6:31 p.m. when the Board went into Closed Session. He was unable to attend the Closed Session and was not present when the Board reconvened in Open Session and voted on this motion.

Before adjourning, the Board was informed by Mr. Clawson that the County has scheduled a meeting involving its beach nourishment engineers and FEMA regarding the Buxton beach nourishment project.

At the conclusion of the meeting, Chairman Woodard asked for a motion to adjourn.

MOTION

Commissioner House motioned to adjourn the meeting.

Commissioner Ross seconded the motion.

VOTE: AYES unanimous (Note: Commissioner Bateman was not present for voting on this item)

At 6:59 p.m., the Board of Commissioners adjourned until 9:00 a.m., February 4, 2019.

Respectfully submitted,

[SEAL]

By: _____
Gary Lee Gross, Clerk to the Board

APPROVED: By: _____
Robert Woodard, Chairman
Dare County Board of Commissioners

Note: copies of all attachments (Att.), ordinances, resolutions, contracts, presentations, and supporting material considered by the Board of Commissioners at this meeting are on file in the office of the Clerk to Board.



*Dare Co DHHS Public Health Division -
Purchase the Shingles Vaccine (Shingrix)*

Description

The DCDHHS Public Health Division has received numerous requests from county employees and members of the community for the Shingles vaccine (Shingrix) and would like to request approval to purchase the Shingrix vaccine. Almost 1 out of every 3 people in the United States will develop shingles. Vaccines can help reduce the risk of getting shingles which is a viral infection that causes a very painful blistering rash. Anyone who has recovered from chickenpox may develop shingles and the risk of getting shingles increases as you get older. The Shingrix vaccine provides strong protection against shingles and the long lasting pain. Shingrix is the preferred vaccine for shingles and 2 doses are required.

No effect on county funding

Board Action Requested

Approve Budget Amendment

Item Presenter

N/A

DARE COUNTY

BUDGET AMENDMENT

F/Y 2018-2019

ACCOUNT	CODE			INCREASE	DECREASE
	Org	Object	Project		

Department:
Human Services-Public Health

Revenues:

Other Revenue - Insurance	103052	464376	41200	\$10,000
---------------------------	--------	--------	-------	----------

Expenditures:

Supplies-Medical	104600	513303	51010	\$10,000
------------------	--------	--------	-------	----------

Explanation:

Purchase the shingles vaccine Shringrix

Approved by:

Board of Commissioners: _____

Date: _____

County Manager: _____

Date: _____

(sign in red)

Finance only:

Date entered: _____ Entered by: _____ Reference number: _____



Sanitation / Budget Amendment to increase Container Purchases Line Item

Description

The Sanitation Container Purchases Expenditure is the line item that trash cans and dumpsters are purchased out of to sell back to home owners and businesses. There are plenty of cans left in inventory to sell to make it through til the end of the fiscal year. The dumpster inventory and can replacement parts inventory, needs to be replenished before the summer season. Spring is the time of year that property management companies repair cans and businesses purchase dumpsters. An estimate of \$50,000 is requested to make sure that we have enough of these items in stock for resale.

Board Action Requested

Approve Budget Amendment

Item Presenter

Shanna Fullmer

DARE COUNTY

BUDGET AMENDMENT

F/Y 2018/2019

ACCOUNT	CODE			INCREASE	DECREASE
	Org	Object	Project		
<u>Department: Sanitation</u>					
<u>Revenues:</u>					
Container Sales	243720	441301		50,000	
<u>Expenditures:</u>					
Container Purchases	244720	515500		50,000	

Explanation:

The Sanitation Container Purchases Expenditure is the line item that trash cans and dumpsters are purchased for resale to the homeowner and businesses. This inventory needs to be re-stocked so that Dare County is able to accomodate home owners and businesses preparing for the summer season.

Approved by:

Board of Commissioners: _____

Date: _____

County Manager: _____

Date: _____

(sign in red)

Finance only:

Date entered: _____ Entered by: _____ Reference number: _____



Water Department NCDOT Three Party Right of Way Encroachment Agreement

Description

The Dare County Water Department is requesting that the NCDOT Three Party Right of Way Encroachment Agreement be approved for a water line and fire hydrant to be placed in front of 1182 Duck Road.

Board Action Requested

Approval of NCDOT Three Party Right of Way Encroachment Agreement.

Item Presenter

Ken Flatt

ROUTE NC 12 PROJECT Parker House Restaurant COUNTY OF STATE OF NORTH CAROLINA Dare

DEPARTMENT OF TRANSPORTATION

THREE PARTY RIGHT OF WAY

-AND-

ENCROACHMENT AGREEMENT ON PRIMARY AND SECONDARY SYSTEM

The Parker House, LLC

2017 Creek Rd., Kitty Hawk, NC 27949

-AND-

Dare County Water Department

600 Mustian Street, Kill Devil Hills, NC 27948

THIS AGREEMENT, made and entered into this the ____ day of ____, 20 19 __, by and between the Department of Transportation, party of the first part; and The Parker House, LLC party of the second part; and Dare County Water Department party of the third part,

WITNESSETH

THAT WHEREAS, the party of the second part desires to encroach on the right of way of the public road designated as Route(s) NC12, located In the Town of Duck On the west side of the road, in front of 1182 Duck Road, approximately 270 feet north of the intersection of Scarborough Lane and NC12 with the construction and/or erection of: Approximately 5' of 6" water main to connect a new fire hydrant located outside of the NC12 R/W with the existing 16" DIP Dare County water main running along the west side of NC12.

WHEREAS, it is to the material advantage of the party of the second part to effect this encroachment, and the party of the first part in the exercise of authority conferred upon it by statute, is willing to permit the encroachment within the limits of the right of way as indicated, subject to the conditions of this agreement;

NOW, THEREFORE, IT IS AGREED that the party of the first part hereby grants to the party of the second part the right and privilege to make this encroachment as shown on attached plan sheet(s), specifications and special provisions which are made a part hereof upon the following conditions, to wit:

That the installation, operation, and maintenance of the above described facility will be accomplished in accordance with the party of the first part's latest POLICIES AND PROCEDURES FOR ACCOMMODATING UTILITIES ON HIGHWAY RIGHTS-OF-WAY, and such revisions and amendments thereto as may be in effect at the date of this agreement. Information as to these policies and procedures may be obtained from the Division Engineer or State Utility Agent of the party of the first part.

That the said party of the second part binds and obligates himself to install and maintain the encroaching facility in such safe and proper condition that it will not interfere with or endanger travel upon said highway, nor obstruct nor interfere with the proper maintenance thereof, to reimburse the party of the first part for the cost incurred for any repairs or maintenance to its roadways and structures necessary due to installation and existence of the facilities of the party of the second part, and if at any time the party of the first part shall require the removal of or changes in the location of the said facilities, that the said party of the second part binds himself, his successors and assigns, to promptly remove or alter the said facilities, in order to conform to the said requirement, without any cost to the party of the first part.

That the party of the second part agrees to provide during construction and any subsequent maintenance proper signs, signal lights, flagmen and other warning devices for the protection of traffic in conformance with the latest Manual on Uniform Traffic Control Devices for Streets and Highways and Amendments or Supplements thereto. Information as to the above rules and regulations may be obtained from the Division Engineer of the party of the first.

That the party of the second part hereby agrees to indemnify and save harmless the party of the first part from all damages and claims for damage that may arise by reason of the installation and maintenance of this encroachment.

That the party of the second part agrees to restore all areas disturbed during installation and maintenance to the satisfaction of the Division Engineer of the party of the first part. The party of the second part agrees to exercise every reasonable precaution during construction and maintenance to prevent eroding of soil; silting or pollution of rivers, streams, lakes, reservoirs, other water impoundments, ground surfaces or other property; or pollution of the air. There shall be compliance with applicable rules and regulations of the North Carolina Division of Environmental Management, North Carolina Sedimentation Control Commission, and with ordinances and regulations of various counties, municipalities and other official agencies relating to pollution prevention and control. When any installation or maintenance operation disturbs the ground surface and existing ground cover, the party of the second part agrees to remove and replace the sod or otherwise reestablish the grass cover to meet the satisfaction of the Division Engineer of the party of the first part.

That the party of the second part agrees to assume the actual cost of any inspection of the work considered to be necessary by the Division Engineer of the party of the first part.

That the party of the second part agrees to have available at the construction site, at all times during construction, a copy of this agreement showing evidence of approval by the party of the first part. The party of the first part reserves the right to stop all work unless evidence of approval can be shown.

Provided the work contained in this agreement is being performed on a completed highway open to traffic; the party of the second part agrees to give written notice to the Division Engineer of the party of the first part when all work contained herein has been completed. Unless specifically requested by the party of the first part, written notice of completion of work on highway projects under construction will not be required.

That in the case of noncompliance with the terms of this agreement by the party of the second part, the party of the first part reserves the right to stop all work until the facility has been brought into compliance or removed from the right of way at no cost to the party of the first part.

That it is agreed by both parties that this agreement shall become void if actual construction of the work contemplated herein is not begun within one (1) year from the date of authorization by the party of the first part unless written waiver is secured by the party of the

second part from the party of the first part.

During the performance of this contract, the second party, for itself, its assignees and successors in interest (hereinafter referred to as the "contractor"), agrees as follows:

- a. Compliance with Regulations: The contractor shall comply with the Regulations relative to nondiscrimination in Federally-assisted programs of the U. S. Department of Transportation, Title 49, Code of Federal Regulations, Part 21, as they may be amended from time to time, (hereinafter referred to as the Regulations), which are herein incorporated by reference and made a part of this contract.
- b. Nondiscrimination: The contractor, with regard to the work performed by it during the contract, shall not discriminate on the grounds of race, color, or national origin in the selection and retention of subcontractors, including procurements of materials and leases of equipment. The contractor shall not participate either directly or indirectly in the discrimination prohibited by Section 21.5 of the Regulations, including employment practices when the contract covers a program set forth in Appendix B of the Regulations.
- c. Solicitations for Subcontracts, including Procurements of Materials and Equipment: In all solicitations either by competitive bidding or negotiation made by the contractor for work to be performed under a subcontract, including procurements of materials or leases of equipment, each potential subcontractor or supplier shall be notified by the contractor of the contractor's obligations under this contract and the Regulations relative to nondiscrimination on the grounds of race, color, or national origin.
- d. Information and Reports: The contractor shall provide all information and reports required by the Regulations, or directives issued pursuant thereto, and shall permit access to its books, records, accounts, other sources of information, and its facilities as may be determined by the Department of Transportation or the Federal Highway Administration to be pertinent to ascertain compliance with such Regulations or directives. Where any information required of a contractor is in the exclusive possession of another who fails or refuses to furnish this information, the contractor shall so certify to the Department of Transportation, or the Federal Highway Administration as appropriate, and shall set forth what efforts it has made to obtain the information.
- e. Sanctions for Noncompliance: In the event of the contractor's noncompliance with the nondiscrimination provisions of this contract, the Department of Transportation shall impose such contract sanctions as it or the Federal Highway Administration may determine to be appropriate, including, but not limited to,
 - (1) withholding of payments to the contractor under the contract until the contractor complies, and/or
 - (2) cancellation, termination or suspension of the contract, in whole or in part.
- f. Incorporation of Provisions: The contractor shall include the provisions of paragraphs "a" through "f" in every subcontract, including procurements of materials and leases of equipment, unless exempt by the Regulations, or directives issued pursuant thereto. The contractor shall take such action with respect to any subcontract or procurement as the Department of Transportation or the Federal Highway Administration may direct as a means of enforcing such provisions including sanctions for noncompliance: Provided, however, that, in the event a contractor becomes involved in, or is threatened with, litigation with a subcontractor or supplier as a result of such direction, the contractor may request the Department of Transportation to enter into such litigation to protect the interests of the State, and, in addition, the contractor may request the United States to enter into such litigation to protect the interests of the United States.

That when title to the subject that constitutes the aforesaid encroachment passes from the party of the second part and vests in the party of the third part, the party of the third part agrees to assume all responsibilities and rights and to perform all obligations as agreed to herein by the party of the second part.

R/W (166) : Party of the Second Part certifies that this agreement is true and accurate copy of the form R/W (166) incorporating all revisions to date.

IN WITNESS WHEREOF, each of the parties to this agreement has caused the same to be executed the day and year first above written.

DEPARTMENT OF TRANSPORTATION

BY: _____
DIVISION ENGINEER

WITNESS:

Parker House, LLC

Second Party

WITNESS:

Dare County Water Department

Third Party



Water Department NCDOT Right of Way Encroachment Agreement

Description

The Dare County Water Department is requesting that the Right of Way Encroachment Agreement be approved for a water line replacement Barley Lane, Frisco.

Board Action Requested

Approval of NCDOT Right of Way Encroachment Agreement.

Item Presenter

Ken Flatt

DEPARTMENT OF TRANSPORTATION

RIGHT OF WAY ENCROACHMENT AGREEMENT

-AND-

PRIMARY AND SECONDARY HIGHWAYS

Dare County

THIS AGREEMENT, made and entered into this the _____ day of _____ 20____ by and between the Department of Transportation, party of the first part; and _____ party of the second part,

WITNESSETH

THAT WHEREAS, the party of the second part desires to encroach on the right of way of the public road designated as Route(s) NC Hwy 12, located On the south side of NC Hwy 12 at the intersection With Barley Lane (a private road) which is approximately 660 feet west of Buxton Back Road (SR 1232) with the construction and/or erection of: Abandonment of an existing 1.5" line crossing from the north side to the south side of Hwy 12, connection to the existing 12" waterline on the south side of Hwy 12 by means of a 6" wet tap, and extension of a new 6" waterline into the Barley Lane r/w.

WHEREAS, it is to the material advantage of the party of the second part to effect this encroachment, and the party of the first part in the exercise of authority conferred upon it by statute, is willing to permit the encroachment within the limits of the right of way as indicated, subject to the conditions of this agreement;

NOW, THEREFORE, IT IS AGREED that the party of the first part hereby grants to the party of the second part the right and privilege to make this encroachment as shown on attached plan sheet(s), specifications and special provisions which are made a part hereof upon the following conditions, to wit:

That the installation, operation, and maintenance of the above described facility will be accomplished in accordance with the party of the first part's latest POLICIES AND PROCEDURES FOR ACCOMMODATING UTILITIES ON HIGHWAY RIGHTS-OF-WAY, and such revisions and amendments thereto as may be in effect at the date of this agreement. Information as to these policies and procedures may be obtained from the Division Engineer or State Utility Agent of the party of the first part.

That the said party of the second part binds and obligates himself to install and maintain the encroaching facility in such safe and proper condition that it will not interfere with or endanger travel upon said highway, nor obstruct nor interfere with the proper maintenance thereof, to reimburse the party of the first part for the cost incurred for any repairs or maintenance to its roadways and structures necessary due to the installation and existence of the facilities of the party of the second part, and if at any time the party of the first part shall require the removal of or changes in the location of the said facilities, that the said party of the second part binds himself, his successors and assigns, to promptly remove or alter the said facilities, in order to conform to the said requirement, without any cost to the party of the first part.

That the party of the second part agrees to provide during construction and any subsequent maintenance proper signs, signal lights, flagmen and other warning devices for the protection of traffic in conformance with the latest Manual on Uniform Traffic Control Devices for Streets and Highways and Amendments or Supplements thereto. Information as to the above rules and regulations may be obtained from the Division Engineer of the party of the first part.

That the party of the second part hereby agrees to indemnify and save harmless the party of the first part from all damages and claims for damage that may arise by reason of the installation and maintenance of this encroachment.

That the party of the second part agrees to restore all areas disturbed during installation and maintenance to the satisfaction of the Division Engineer of the party of the first part. The party of the second part agrees to exercise every reasonable precaution during construction and maintenance to prevent eroding of soil; silting or pollution of rivers, streams, lakes, reservoirs, other water impoundments, ground surfaces or other property; or pollution of the air. There shall be compliance with applicable rules and regulations of the North Carolina Division of Environmental Management, North Carolina Sedimentation Control Commission, and with ordinances and regulations of various counties, municipalities and other official agencies relating to pollution prevention and control. When any installation or maintenance operation disturbs the ground surface and existing ground cover, the party of the second part agrees to remove and replace the sod or otherwise reestablish the grass cover to meet the satisfaction of the Division Engineer of the party of the first part.

That the party of the second part agrees to assume the actual cost of any inspection of the work considered to be necessary by the Division Engineer of the party of the first part.

That the party of the second part agrees to have available at the construction site, at all times during construction, a copy of this agreement showing evidence of approval by the party of the first part. The party of the first part reserves the right to stop all work unless evidence of approval can be shown.

Provided the work contained in this agreement is being performed on a completed highway open to traffic; the party of the second part agrees to give written notice to the Division Engineer of the party of the first part when all work contained herein has been completed. Unless specifically requested by the party of the first part, written notice of completion of work on highway projects under construction will not be required.

That in the case of noncompliance with the terms of this agreement by the party of the second part, the party of the first part reserves the right to stop all work until the facility has been brought into compliance or removed from the right of way at no cost to the party of the first part.

That it is agreed by both parties that this agreement shall become void if actual construction of the work contemplated herein is not begun within one (1) year from the date of authorization by the party of the first part unless written waiver is secured by the party of the second part from the party of the first part.

During the performance of this contract, the second party, for itself, its assignees and successors in interest (hereinafter referred to as the "contractor"), agrees as follows:

- a. Compliance with Regulations: The contractor shall comply with the Regulations relative to nondiscrimination in Federally-assisted programs of the U. S. Department of Transportation, Title 49, Code of Federal Regulations, Part 21, as they may be amended from time to time, (hereinafter referred to as the Regulations), which are herein incorporated by reference and made a part of this contract.
- b. Nondiscrimination: The contractor, with regard to the work performed by it during the contract, shall not discriminate on the grounds of race, color, or national origin in the selection and retention of subcontractors, including procurements of materials

and leases of equipment. The contractor shall not participate either directly or indirectly in the discrimination prohibited by Section 21.5 of the Regulations, including employment practices when the contract covers a program set forth in Appendix B of the Regulations.

- c. Solicitations for Subcontracts, including Procurements of Materials and Equipment: In all solicitations either by competitive bidding or negotiation made by the contractor for work to be performed under a subcontract, including procurements of materials or leases of equipment, each potential subcontractor or supplier shall be notified by the contractor of the contractor's obligations under this contract and the Regulations relative to nondiscrimination on the grounds of race, color, or national origin.
- d. Information and Reports: The contractor shall provide all information and reports required by the Regulations, or directives issued pursuant thereto, and shall permit access to its books, records, accounts, other sources of information, and its facilities as may be determined by the Department of Transportation or the Federal Highway Administration to be pertinent to ascertain compliance with such Regulations or directives. Where any information required of a contractor is in the exclusive possession of another who fails or refuses to furnish this information, the contractor shall so certify to the Department of Transportation, or the Federal Highway Administration as appropriate, and shall set forth what efforts it has made to obtain the information.
- e. Sanctions for Noncompliance: In the event of the contractor's noncompliance with the nondiscrimination provisions of this contract, the Department of Transportation shall impose such contract sanctions as it or the Federal Highway Administration may determine to be appropriate, including, but not limited to,
 - (1) withholding of payments to the contractor under the contract until the contractor complies, and/or
 - (2) cancellation, termination or suspension of the contract, in whole or in part.
- f. Incorporation of Provisions: The contractor shall include the provisions of paragraphs "a" through "f" in every subcontract, including procurements of materials and leases of equipment, unless exempt by the Regulations, or directives issued pursuant thereto. The contractor shall take such action with respect to any subcontract or procurement as the Department of Transportation or the Federal Highway Administration may direct as a means of enforcing such provisions including sanctions for noncompliance: Provided, however, that, in the event a contractor becomes involved in, or is threatened with, litigation with a subcontractor or supplier as a result of such direction, the contractor may request the Department of Transportation to enter into such litigation to protect the interests of the State, and, in addition, the contractor may request the United States to enter into such litigation to protect the interests of the United States.

R/W (161) : Party of the Second Part certifies that this agreement is true and accurate copy of the form R/W (161) incorporating all revisions to date.

IN WITNESS WHEREOF, each of the parties to this agreement has caused the same to be executed the day and year first above written.

DEPARTMENT OF TRANSPORTATION

BY: _____
DIVISION ENGINEER

ATTEST OR WITNESS:

Dare County

Dare County

Second Party

INSTRUCTIONS

When the applicant is a corporation or a municipality, this agreement must have the corporate seal and be attested by the corporation secretary or by the empowered city official, unless a waiver of corporate seal and attestation by the secretary or by the empowered City official is on file in the Raleigh office of the Manager of Right of Way. In the space provided in this agreement for execution, the name of the corporation or municipality shall be typed above the name, and title of all persons signing the agreement should be typed directly below their signature.

When the applicant is not a corporation, then his signature must be witnessed by one person. The address should be included in this agreement and the names of all persons signing the agreement should be typed directly below their signature.

This agreement must be accompanied, in the form of an attachment, by plans or drawings showing the following applicable information:

1. All roadways and ramps.
2. Right of way lines and where applicable, the control of access lines.
3. Location of the existing and/or proposed encroachment.
4. Length, size and type of encroachment.
5. Method of installation.
6. Dimensions showing the distance from the encroachment to edge of pavement, shoulders, etc.
7. Location by highway survey station number. If station number cannot be obtained, location should be shown by distance from some identifiable point, such as a bridge, road, intersection, etc. (To assist in preparation of the encroachment plan, the Department's roadway plans may be seen at the various Highway Division Offices, or at the Raleigh office.)
8. Drainage structures or bridges if affected by encroachment (show vertical and horizontal dimensions from encroachment to nearest part of structure).
9. Method of attachment to drainage structures or bridges.
10. Manhole design.
11. On underground utilities, the depth of bury under all traveled lanes, shoulders, ditches, sidewalks, etc.
12. Length, size and type of encasement where required.
13. On underground crossings, notation as to method of crossing - boring and jacking, open cut, etc.
14. Location of vents.

GENERAL REQUIREMENTS

1. Any attachment to a bridge or other drainage structure must be approved by the Head of Structure Design in Raleigh prior to submission of encroachment agreement to the Division Engineer.
2. All crossings should be as near as possible normal to the centerline of the highway.
3. Minimum vertical clearances of overhead wires and cables above all roadways must conform to clearances set out in the National Electric Safety Code.
4. Encasements shall extend from ditch line to ditch line in cut sections and 5' beyond toe of slopes in fill sections.
5. All vents should be extended to the right of way line or as otherwise required by the Department.
6. All pipe encasements as to material and strength shall meet the standards and specifications of the Department.
7. Any special provisions or specifications as to the performance of the work or the method of construction that may be required by the Department must be shown on a separate sheet attached to encroachment agreement provided that such information cannot be shown on plans or drawings.
8. The Department's Division Engineer should be given notice by the applicant prior to actual starting of installation included in this agreement.



Water Department Budget Amendment

Description

The Dare County Water Department is requesting that funds be moved from Water Distribution Capital Outlay to Water Distribution Maintenance & Repair to complete a chlorine feeding project.

Board Action Requested

Approval of the fund transfer

Item Presenter

Ken Flatt

DARE COUNTY

BUDGET AMENDMENT

F/Y 2018/2019

ACCOUNT	CODE			INCREASE	DECREASE
	Org	Object	Project		
<u>Department: Water</u>					
<u>Revenues:</u>					
Capital Outlay	364815	537400			17,233
 <u>Expenditures:</u>					
Maintenance & Repair	364815	511501	36002	17,233	

Explanation:

Funds remained in Water Distribution Capital Outlay after all projects were completed. The Water Department is requesting to move these funds to Water Distribution Maintenance & Repair to complete a chemical feeding equipment change from gas chlorine to sodium hypochlorite for operator safety.

Approved by:

Board of Commissioners: _____

Date: _____

County Manager: _____

Date: _____

(sign in red)

Finance only:

Date entered: _____ Entered by: _____ Reference number: _____



Advertise 2018 Tax Year Liens

Description

The total unpaid taxes as of January 28, 2019 on Real Estate are \$ 3,725,907.67. The Tax Collector will advertise unpaid taxes on Real Estate in the March 6, 2019 edition of the Coastland Times.

Board Action Requested

Order the Tax Collector to advertise the 2018 Real Estate tax liens.

Item Presenter

Becky Huff, Tax Collector



Board Appointments

Description

The Dare County Board of Commissioners will consider the following Board Appointments:

- Aging Advisory Council
- Older Adult Services Advisory Council
- Planning Board
- Senior Tar Heel Legislative Delegates

Complete information about the appointments will appear after this page.

Upcoming Board Appointments for the next three months are listed at the end.

Board Action Requested

Make Board Appointments and Announce Upcoming Appointments

Item Presenter

Robert Outten, County Manager

BOARD APPOINTMENT SUMMARY – February 4, 2019

Aging Advisory Council

- The following terms expire this month:
Brandi Rheubottom
Kaye White
- Both would like to be reappointed.
- No other applications have been received.

Older Adult Services Advisory Council

- Paulette Prodanchek has resigned.
- An application has been received from Craig Albert.
- The Older Adult Services Advisory Council recommends that Craig Albert be appointed to replace Paulette Prodanchek.

Planning Board

- Terry Gore's term expires this month. He would like to be reappointed.
- Jeff Landreth has resigned from the Planning Board and does not want to be reappointed.
- Applications that qualify for the At Large seat have been received from:
Aida Havel, A. Gordon (Don) Milbrath, Allen Moran, William J. Overman, Jr.,
James R. "Buddy" Shelton, Colleen Shriver, John Towler
- Applications that qualify for the District One seat have been received from:
Allen Moran, William J. Overman, Jr., James R. "Buddy" Shelton, Colleen Shriver

Senior Tar Heel Legislative Delegates

- Kaye White, Delegate and Mary Ellen Hawthorne, Alternate have terms that expire in February
- Both would like to be reappointed
- No other applications have been received

UPCOMING BOARD APPOINTMENTS

March: Parks and Recreation Advisory Council

April: Airport Authority
Manns Harbor Commission

May: Veterans Advisory Council
Zoning Board of Adjustment – Dare County



Aging Advisory Council

Description

See Attached Summary

Board Action Requested

Take Appropriate Action

Item Presenter

Robert Outten, County Manager

February 2019

BOARD APPOINTMENTS

AGING ADVISORY COUNCIL FOR THE ALBEMARLE COMMISSION
(Two Year Term)

The following have terms to expire this month:

Brandi Rheubottom
(Current Term 2/17 – 2/19)
(Originally Apptd. 2/01)

Kaye White
(Current Term 2/17 – 2/19)
(Originally Apptd. 2/11)

Both would like to be reappointed.

No other applications have been received.

Other members:
See attached list

AGING ADVISORY COUNCIL FOR THE ALBEMARLE COMMISSION

(Two Year Term)

The Aging Advisory Council advocates on behalf of the senior population in their counties by reviewing and commenting on the laws, policies, actions and programs that affect older adults.

<u>MEMBER</u>	<u>TERM EXPIRATION</u>	<u>ACTION</u>
Brandi Rheubottom Older Adult Services Director P.O. Box 1000 Manteo, NC 27954 475-5636 Nags Head Township	2/19	Apptd. 2/01 Reapptd.2/03,05,07,09, 11,13,15,17
Kaye White 423 W. Villa Dunes Dr. Nags Head, NC 27959 441-7062 Atlantic Township	2/19	Apptd. 2/11 Reapptd.2/13,15,17

NOTES: Meeting Date – Quarterly on a called basis
Albemarle Commission
Hertford, NC

Emma Jane McDermott replaced Clinton Crawford 2/93.
Brandi Rheubottom replaced Jay Burrus 2/01.
Bel Pitcher filled the unexpired term of Emma Jane McDermott 9/03.
Kaye White filled vacant seat (Bel Pitcher) 2/11.

REVISED 2/17



Older Adult Services Advisory Council

Description

See Attached Summary

Board Action Requested

Take Appropriate Action

Item Presenter

Robert Outten, County Manager

February 2019

Board Appointment
Older Adult Services Advisory Council
(Four Year Term)

The following has resigned from the Board:

Paulette Prodanchek
(North Beach Area Rep.)
(Current Term 11/17 - 11/21)
(Originally Apptd. 04/05)

An Application has been received from Craig Albert.

The Older Adult Services Advisory Council recommends that
Craig Albert be appointed to replace Paulette Prodanchek.

Other Members:
See attached list

APPLICATION FOR APPOINTMENT TO
DARE COUNTY ADVISORY BOARDS AND COMMITTEES

The Dare County Board of Commissioners believes all citizens should have the opportunity to participate in governmental decisions. One way of participating is by serving as a citizen member on one of the county's advisory boards or committees. If you would like to be considered for appointment to an advisory board or committee, please complete the form below and mail to Janice Williams, P.O. Box 1000, Manteo, N.C. 27954 or fax it to her at 473-1817, or send it by email to janicew@darenc.com

Advisory Board or Committee Interested in:

1st choice DARE COUNTY OLDER ADULTS SERVICES ADVISORY
2nd choice JUVENILE SERVICES; JUVENILE COURT; TEEN COUNSEL
3rd choice _____

Name CRAIG S. ALBERT
Address 74 GRAVEY POND LANE
City/State/Zip SOUTHERN SHORES, N.C. 27949
Email Address graveypond@yahoo.com
Telephone Home: (410) 666-2208
Business: _____

Resident of Dare County: yes no

Occupation: Retired

Business Address: _____

Educational background:
J.D. - UNIV. OF TEXAS LAW SCHOOL
BBA - UNIV. OF CINCINNATI

Business and civic experience and skills:
Judge, GAUSA County, Ohio - 16 years
COUNTY PROSECUTOR GAUSA COUNTY - 8 years

Other Boards/Committees/Commissions on which you presently serve:

REFERENCES

List three persons who are not related to you and who have definite knowledge of your qualifications for the position for which you are applying.

Name	Business/Occupation	Address	Telephone
URSULA BATEMAN		360 SEA OATS TRAIL	252 261-1617
EMILY GOULD	BAUM CENTER	P.O. BOX 1000	MANTO, 27954

I understand this application will be kept on the active file for three years and I hereby authorize Dare County to verify all information included in this application.

Date: 12/18/18 Signature of applicant: Craig B. Albert

FOR OFFICE USE ONLY:

Date received: 1-9-19

OLDER ADULT SERVICES ADVISORY COUNCIL

(Four Year Term)

This Council advises Dare County in its efforts to promote, organize, plan, and coordinate services and programs for residents and visitors to Dare County who are 55 years of age and older.

<u>MEMBER</u>	<u>TERM EXPIRATION</u>	<u>ACTION</u>
Linda Lengyel P.O. Box 211 Hatteras, NC 27943 937-623-3258 North Hatteras Island Area	11-22	Apptd. 3/13 Reapptd. 11/14, 18
Mary Pendill 129 Dogwood Circle Manteo, NC 27954 252-423-0757 (Cell), 252-473-3589 (H) -Manteo Area	11-22	Apptd. 11/14 Reapptd. 11/18
Cynthia Harris, Chair. 92 S. Dogwood Trail Southern Shores, NC 27949 703-402-6288 South Beach Area	11-21	Apptd. 11/15 Reapptd 11/17
Melissa Turnage 108 Rhodoms Dr. Kill Devil Hills, NC 27948 256-0026 (H) 475-5585 (O) Social Services Rep.	11-22	Apptd. 12-16 Reapptd. 11/18
Lynne Bloomfield, Vice Chair. 5024 Lindbergh Ave. Kitty Hawk, NC 27949 261-8937 (H) lrbloomfieldkhnc@charter.net Adult Services Rep.	11-19	Apptd. 11/14 Reapptd. 11/15
Kenneth Bukantas 288 Wax Myrtle Trail Southern Shores, NC 27949 261-7322 (H) Ken.bukantas@outlook.com Adult Services Rep.	11-21	Apptd. 1/19

<p>Paulette Prodanchek 46 Mistletoe Lane Kitty Hawk, NC 27949 261-0676 North Beach Area</p>	<p>11-21</p>	<p>Apptd. 4-05 Reaptd. 11-05,09,13,17</p>
<p>Vacant Mainland Area</p>	<p>11-17</p>	<p>Apptd. 11/15</p>
<p>Claudia Hennessey P.O. Box 740 Avon, NC 27915 995-6662 Wanchese Area</p>	<p>11-21</p>	<p>Apptd. 11/15 Reaptd. 11/17</p>
<p>John Clark 216 Harbour Rd. Kill Devil Hills, NC 27948 715-0284 Central Beach Area</p>	<p>11-20</p>	<p>Apptd. 11/16</p>
<p>Jim Tobin 6951 Pecan Lane PO Box 243 Manns Harbor, NC 27953 Jim.tobin@darenc.com 216-7732 DC Commissioner</p>	<p>1-21</p>	<p>Apptd 6/17</p>

NOTE:

MEETING INFO: 2nd Wednesday, 10:00 a.m., except June, July, Aug. Meetings rotates between Baum Center, Dare Center and Fessenden Center

CONTACT INFO: Cindy Harris, Chair
Lynne Bloomfield, Vice Chair
Brandi Rheubottom, Dir., Baum Center

MEMBERS COMPENSATED: No

Commissioner Byrd replaced Commissioner Perry 9/97.
Walter Parker replaced Herb Barr 11/97.
Josephine Fessler replaced Lovie Midgett 11/97.
Alpean Midgett apptd. to fill unexpired term of Louise Rossiter who resigned 11/97.

Henry Haywood apptd. to fill unexpired term Marge Keys 3/99.
Edna P. Fehrmann apptd. to fill unexpired term of Marge Keys 3/99.
Kathy Crowder replaced Jimmy Williams 11/99.
Marjorie Midgett replaced Roy Midgett 11/99.
Grace Fruit replaced Edna Fehrmann 10/00.
Cheryl Byrd's appt. tabled til 12/18/00.
Geneva H. Perry filled unexpired term of Comm. Cheryl Byrd 1/01.
Lovie Midgett apptd. to fill unexpired term of Alpean Midgett 4/01.
Shirley Venente replaced Walter Parker 1/02.
Barbara Brenner replaced Josephine Fessler 1/02.
Mary Conway replaced Dell Collins 1/03.
Jonna Midgett replaced Sue Judge 1/03.
Virginia Tillett filled unexpired term of outgoing Comm. Geneva Perry 2/03.
Joe Rongo replaced "Fritz" Winfree 11/03.
Annie Rose Wells filled unexpired term of Gee Fruit 3/04.
Paulette Prodanchek filled unexpired term of Barbara Brenner 4/05.
Lynda Hester filled unexpired term of Mary Conway 4/07.
Lynn Thomas filled unexpired term of Joe Rongo 8/07.
Georgia Ellis filled unexpired term of Annie Rose Wells 8/07.
Judith Link filled unexpired term of Shirley Venente 5/08.
Steve Jennette filled unexpired term of Lovie Midgett 12/08. Gisele Mead filled unexpired term of Lynda Hester 1/09.
Linda Lenguel filled unexpired term of Steve Jennette 3/04.
Lynn Bloomfield filled unexpired term of Julia Haywood 11/14.
David Faudie filled unexpired term of Betse Kelly 11/14.
Margarette Umphlett filled unexpired term of Virginia Tillett 12/14.
***11/2/15 – Cynthia Harris apptd. to South Beach seat, Sandra Clark to Mainland seat and Claudia Hennessey apptd. to Wanchese seat for two year terms. There were no applications from these designated areas, so appointments were made from applications that were on hand.
John Clark replaced Georgia Ellis 11/16.
Melissa Turnage filled unexpired term of Jonna Midgett 12/16.
Jim Tobin appointed to fill unexpired term of Margarette Umphlett 6/17
Sandra Clark did not want to be reappointed 11/17
Kenneth Bukantas replaced David Faudie who resigned 1/19

REVISED 1/19



Planning Board

Description

See Attached Summary

Board Action Requested

Take Appropriate Action

Item Presenter

Robert Outten, County Manager

February, 2019

BOARD APPOINTMENTS

PLANNING BOARD

(Three Year Term)

The following have terms to expire this month:

Terry Gore

(At Large)

(Current Term 2/16 – 2/19)

(Originally Apptd. 2/16)

Jeff Landreth

(District One)

(Current Term 6/16– 2/19)

(Originally Apptd. 6/16)

Terry Gore would like to be reappointed.

Jeff Landreth has resigned and does not want to be reappointed.

Applications that qualify for the At Large seat have been received from:

Aida Doss Havel

A. Gordon (Don) Milbrath

Allen Moran

William J. Overman, Jr.

James R. "Buddy" Shelton

Colleen R. Shriver

John Towler

Applications that qualify for the District One seat have been received from:

Allen Moran

William J. Overman, Jr.

James R. "Buddy" Shelton

Colleen R. Shriver

Other Members: See attached list

APPLICATION FOR APPOINTMENT TO
DARE COUNTY ADVISORY BOARDS AND COMMITTEES

The Dare County Board of Commissioners believes all citizens should have the opportunity to participate in governmental decisions. One way of participating is by serving as a citizen member on one of the county's advisory boards or committees. If you would like to be considered for appointment to an advisory board or committee, please complete the form below and mail to Janice Williams, P.O. Box 1000, Manteo, N.C. 27954 or fax it to her at 473-1817, or send it by email to janicew@darenc.com

DIST. 4

Advisory Board or Committee interested in:

1st choice Albemarle Commission

2nd choice Tourism Board

3rd choice Planning Board

Name Aida Doss Havel

Address P.O. Box 676

City/State/Zip Rodanthe, NC 27968

Email Address aidahavel@gmail.com

Telephone Home: 919-740-7031

Business: same

Resident of Dare County: yes no

Occupation: Attorney

Business Address: (same as above)

Educational background:

BA, Davidson College, 1980; J.D., UNC-Chapel Hill, 1984;

Masters in Conflict Resolution, UNC-G, 2015

Business and civic experience and skills:

- ① 30+ years in the legal system, first as a litigator, now as a mediator and peacemaker
- ② Extensive election administration experience, including 4 years on the Wake County Board of Elections, the last 2 as chair.
- ③ Extensive Board experience, including chair/president

of Friends of the Outer Banks History Center and
Unity Church of the Triangle.

④ Extensive board & committee service in multiple
legal organizations, including the Wake County Bar
Association and the NC Bar Association.
Other Boards/Committees/Commissions on which you presently serve:

Because I have just recently moved to Dare
County, I do not presently serve on any boards
or commissions but I would very much
like to get involved (which is why I am making
this application).

REFERENCES

List three persons who are not related to you and who have definite knowledge of your
qualifications for the position for which you are applying.

Name	Business/Occupation	Address	Telephone
Mr. Danny Couch	Commissioner/Realtor		252-475-4477
Mr. Gary Sims	Director, Wake County Board of Elections		919-856-6240
Ms. Tama Creel	Archivist, Outer Banks History Center		252-473-2655

I understand this application will be kept on the active file for three years and I
hereby authorize Dare County to verify all information included in this application.

Date: 12/12/18 Signature of applicant: [Signature]

FOR OFFICE USE ONLY:

Date received: 12-14-18

AIDA DOSS HAVEL

P.O. Box 676

Rodanthe, North Carolina 27968

(919) 740-7031

www.havellaw.com, aida@havellaw.com, aidahavel@gmail.com

EDUCATION

- B.A., Davidson College, Davidson, North Carolina, 1980
- Certificate, University of Denver Publishing Institute, Denver, Colorado, 1980
- J.D., UNC School of Law, Chapel Hill, North Carolina, 1984
- Master's Degree in Peace and Conflict Studies, UNC-G, Greensboro, North Carolina, 2015

LAW SCHOOL ACTIVITIES

- North Carolina Law Review
- Medical Conditions Supervisor, Prisoners' Rights Project
- International Moot Court participant

MEMBERSHIPS

- North Carolina State Bar (admitted 1985)
- North Carolina Bar Association (Family Law and Dispute Resolution sections; current Co-Chair of The Civil Collaborative Committee of the Dispute Resolution section)
- Wake County Bar Association
- International Academy of Collaborative Professionals
- Global Collaborative Law Council

EMPLOYMENT

- **Participating Attorney**, Just Us (a collaborative law practice group) November 2018 - present
- **Participating Attorney**, Separating Together (a collaborative law practice group) November 2010 - November 2018
- **Attorney at Law**, Law Offices of Aida Doss Havel, January 2006 - October 2010
- **Attorney & Senior Partner**, Doss & Willis, L.L.P., August 1992 - December 2005
- **Associate Attorney**, Stratas & Weathers, October 1989 - July 1992
- **Associate Attorney**, Faison & Brown, October 1988 - September 1989
- **Attorney at Law**, Law Offices of Aida Fayar Doss, January 1987 - September 1988
- **Staff Attorney**, North Carolina Court of Appeals, March 1985 - December 1986
- **Marketing Assistant**, Harper & Row Publishers, New York, NY, September 1980 - May 1981

LEGAL ACTIVITIES AND HONORS

- Presentation to ABA Dispute Resolution Section annual meeting (anticipated April 2019)
- Presentations to two national collaborative law organizations (GCLC and IACP), 2018
- Course Planner and presenter/trainer at 5+ CLE seminars across North Carolina, 2016-2018
- Board Member, **Wake County Bar Association**, 2016-2018
- With the Honorable Christine Walczyk, Wake County District Court Judge, created and implemented a new volunteer mediation program in Family Court, 2015

- Presentation on Collaborative Law to students, faculty, and attorneys at UNC-Charlotte School of Law, 2015
- With the Honorable Jennifer M. Green, Wake County District Court Judge, created and implemented a new court to mediate custody claims in domestic violence cases, 2013-2014
- Taught family law, collaborative law, and elections law to a visiting group of mediators from Belarus, April 2014
- Co-taught a 15-hour Basic Collaborative Law course, April 2014, April 2015, Spring 2017
- Taught mediation to a co-housing group, January 2014
- Authored "Ten Things You Probably Didn't Know About Collaborative Law" for the December 2013 issue of the NC Advocates for Justice' *Trial Briefs* magazine
- Participant in panel presentation on "The Paradigm Shift" at Campbell Law School Symposium on "The Virtuous Lawyer," 2013
- IACT Leadership Committee (www.iactprogram.com), July 2011 – present
- Team taught two multi-day seminars (3 days and 4 days) on Collaborative Law in the Health Care Context, 2011 and 2012
- Presentation on Collaborative Law to family law class at NC Central School of Law, 2010, 2011, and 2012
- Ongoing presentations about NC family law to mediators seeking certification as Family Financial Mediators, 2010-present
- Participant, NCBA's "4All" Day of Service call-in program, 2009, 2010, 2012, and 2014
- Presentation on "Financial Issues in Family Law" to Triangle Pastoral Counseling, 2009
- Presentation on "Starting Your Own Family Law Practice" to the NC Advocates for Justice (formerly Academy of Trial Lawyers), 2008
- Ongoing presentations to women in recovery at The Healing Place, 2008 - 2010
- Wake County Family Court Improvement Committee, 2007 – present
- Original Bench/Bar Transitional Family Court Committee, 2002
- Women's Center Legal Hotline, 1990 - 2003
- President, Wake County Family Lawyers, 1990 – 1991
- Outstanding Volunteer Lawyer Award, 1996
- Taught seminar on Family Law for attorneys, 1993
- Lectured to various paralegal classes on Family Law, early 1990s
- Lectured to State government employees on wills and other estate documents, early 1990s

ADVANCED LEGAL TRAINING

- Trained in Advanced Non-Violent Communication, 2010, 2012
- Trained in Advanced Collaborative Law, 2008
- Trained as a Parent Coordinator, 2007
- Trained in Non-Violent Communication, 2007
- Trained as a Family Financial Mediator, 2006
- Trained in Collaborative Law, 2005

CIVIC INVOLVEMENT

- **Dare County Board of Elections** precinct official, May 2018 – present
- **Wake County Board of Elections** Coordinator, July 2014 – November 2016
- Authored "A Handbook for New County Board of Elections Members in North Carolina," August 2013; presented copies to all 300 county Board of Elections' members
- Presentation on "County Board Members 101: What You Need to Know" at statewide training for 300 county board of elections members, August 2013
- Chair, Wake County Board of Elections, July 2011 – July 2013
- Secretary, Wake County Board of Elections, July 2009 – June 2011

- **Legislative Liaison**, Election Boards Association of North Carolina, July 2009 – July 2013
- **Chief Judge** in Precinct 11-02, August 2007 – July 2009
- **Wake County Board of Elections** precinct official in Precinct 11-02, 1994 – July 2009
- President, Board of Trustees, **Unity Church of the Triangle**, April 2011 – March 2012 (Vice-President, June 2010 – March 2011; member at large, March 2010 – June 2010, March 2012 – March 2013)
- Board Member, **Friends of the Outer Banks History Center**, November 2011 -- present
- Board Member, **Triangle Pastoral Counseling**, 2008 - 2011
- Board Member, **NC-GALA** (Gay and Lesbian Attorneys), 2007 - present
- Ongoing participation in **Capital Area Teen Court**, 2013 – 2015
- Participated in tutoring relocated Montagnard parents and children, February 2013 – December 2014
- Participated in remodeling a disabled child's bedroom with April's Angels in Pittsboro, North Carolina, May 2012
- Participated in a support circle for a local homeless family through Unity Church of the Triangle and Catholic Charities, 2010-2011
- Participated in rebuilding a Katrina-destroyed home with the St. Bernard Project in Chalmette, Louisiana, May 2009

POLITICAL ACTIVITIES

- Member, Dare County Democratic Party and Dare County Democratic Women, May 2018 – present
- Secretary, Wake County Democratic Party, January 2009 – April 2009 (resigned due to a statutory conflict)
- Member, Wake County Democratic Women, 2006 - 2009
- Member, Lillian's List, 2004 – 2009
- Member, ACLU, 2004 – 2009
- Member, League of Women Voters, 2004 – 2009

PERSONAL

- Married to John M. Havel; one stepson; two cats

APPLICATION FOR APPOINTMENT TO
DARE COUNTY ADVISORY BOARDS AND COMMITTEES

The Dare County Board of Commissioners believes all citizens should have the opportunity to participate in governmental decisions. One way of participating is by serving as a citizen member on one of the county's advisory boards or committees. If you would like to be considered for appointment to an advisory board or committee, please complete the form below and mail to Janice Williams, P.O. Box 1000, Manteo, N.C. 27954 or fax it to her at 473-1817, or send it by email to janicew@darenc.com

Advisory Board or Committee interested in:

1st choice Airport Authority

2nd choice Waterways Commission

3rd choice Planning Board

Name A. Gordon (Don) Milbrath

Address 2711 S. Virginia Dare Trail

City/State/Zip Nags Head NC 27959

Email Address milbrathdon@gmail.com

Telephone Home: 252/441-2108

Business: 303/908-1579

Resident of Dare County: yes no

Occupation: Consultant/Restaurateur

Business Address: Colorado

Educational background:

BS In Business Admin, UNC at Chapel Hill

numerous graduate level courses incl. National Defense Unisversity, Naval War College

Business and civic experience and skills:

resume available upon request. Chairman Greenwood Village (CO)

Planning Board, President, Special Tax District (CO)

Other Boards/Committees/Commissions on which you presently serve:

Nags Head Board of Adjustments

REFERENCES

List three persons who are not related to you and who have definite knowledge of your qualifications for the position for which you are applying.

Name	Business/Occupation	Address	Telephone
<u>Charles Evans, Attorney, Manteo, 252/256-0545</u>			
<u>Melanie Smith, Business Owner, Kill Devil Hills, 252/441-5418</u>			
<u>Kevin Zorc, Fire Chief, Nags Head, 252/441-5909</u>			

I understand this application will be kept on the active file for three years and I hereby authorize Dare County to verify all information included in this application.

Date: 9/20/17 Signature of applicant: A. Gordon McDonald

FOR OFFICE USE ONLY:

Date received: 9/20/17

APPLICATION FOR APPOINTMENT TO
DARE COUNTY ADVISORY BOARDS AND COMMITTEES

The Dare County Board of Commissioners believes all citizens should have the opportunity to participate in governmental decisions. One way of participating is by serving as a citizen member on one of the county's advisory boards or committees. If you would like to be considered for appointment to an advisory board or committee, please complete the form below and mail to Janice Williams, P.O. Box 1000, Manteo, N.C. 27954 or fax it to her at 473-1817, or send it by email to janicew@darenc.com

Advisory Board or Committee interested in:

1st choice Planning Board 4.) Board of Adjustment

2nd choice ABC Board 5.) Equalization & Review

3rd choice Tourism Board 6.) Health & Human Services

Name Allen Moran

Address 381 Mother Vineyard Rd

City/State/Zip Manteo, NC 27954

Email Address allenm@darenc.com

Telephone Home: (252) 423-1309

Business: (252) 475-9222

Resident of Dare County: yes no

Occupation: Police Officer / Real Estate Broker / Restaurateur

Business Address: 7623 S. Virginia Dare Trl Nags Head, NC

Educational background:

NC licensed real estate broker, NC Justice Academy,

College of the Albemarle

Business and civic experience and skills:

Rotary International Community Service Chair (Manteo, 2012),

U.S. Restaurant Association Board Member

Other Boards/Committees/Commissions on which you presently serve:

NCOT Board, Roanoke Island Community Center,
Albemarle Regional Planning Organization,
Peanut Belt Regional Planning Organization

REFERENCES

List three persons who are not related to you and who have definite knowledge of your qualifications for the position for which you are applying.

Name	Business/Occupation	Address	Telephone
<u>RV Owens</u>	<u>Self-Employed</u>	<u>Manteo, NC</u>	<u>216-8079</u>
<u>Doug Daughtie</u>	<u>Sheriff (Dare)</u>	<u>KDH, NC</u>	<u>216-9898</u>
<u>Marc Basnight</u>	<u>Retired</u>	<u>Manteo, NC</u>	<u>216-6703</u>

I understand this application will be kept on the active file for three years and I hereby authorize Dare County to verify all information included in this application.

Date: 02/02/2018 Signature of applicant: 

FOR OFFICE USE ONLY:

Date received: _____

Other Boards/Committees/Commissions on which you presently serve:

NONE

REFERENCES

List three persons who are not related to you and who have definite knowledge of your qualifications for the position for which you are applying.

Name	Business/Occupation	Address	Telephone
<u>CLARENCE SKINNER</u>			
<u>Dr CHARLES DAVIDSON</u>			
<u>day wheelers</u>			

I understand this application will be kept on the active file for three years and I hereby authorize Dare County to verify all information included in this application.

Date: 1/26/17 Signature of applicant: [Signature]

FOR OFFICE USE ONLY:

Date received: 1/26/17

APPLICATION FOR APPOINTMENT TO
DARE COUNTY ADVISORY BOARDS AND COMMITTEES

The Dare County Board of Commissioners believes all citizens should have the opportunity to participate in governmental decisions. One way of participating is by serving as a citizen member on one of the county's advisory boards or committees. If you would like to be considered for appointment to an advisory board or committee, please complete the form below and mail to Janice Williams, P.O. Box 1000, Manteo, N.C. 27954 or fax it to her at 473-1817, or send it by email to janicew@darenc.com

Advisory Board or Committee interested in:

1st choice Planning Board

2nd choice ~~Game & Wildlife Board~~

3rd choice _____

Name James R "Buddy" Shelton

Address 291 Bayview Dr.

City/State/Zip Stumpy Point

Email Address buddy.shelton1959@gmail.com

Telephone Home: 252-473-5572

Business: 423-8659

Resident of Dare County: yes no

Occupation: Building Inspector

Business Address: Southern Shores

Educational background:

Business and civic experience and skills:

Other Boards/Committees/Commissions on which you presently serve:

Game & Wildlife Board

REFERENCES

List three persons who are not related to you and who have definite knowledge of your qualifications for the position for which you are applying.

Name	Business/Occupation	Address	Telephone
_____	_____	_____	_____
_____	_____	_____	_____
_____	_____	_____	_____

I understand this application will be kept on the active file for three years and I hereby authorize Dare County to verify all information included in this application.

Date: 3-13-18 Signature of applicant: *James P. Shelton*

FOR OFFICE USE ONLY:

Date received: 3-13-18

APPLICATION FOR APPOINTMENT TO
DARE COUNTY ADVISORY BOARDS AND COMMITTEES

The Dare County Board of Commissioners believes all citizens should have the opportunity to participate in governmental decisions. One way of participating is by serving as a citizen member on one of the county's advisory boards or committees. If you would like to be considered for appointment to an advisory board or committee, please complete the form below and mail to Janice Williams, P.O. Box 1000, Manteo, N.C. 27954 or fax it to her at 473-1817, or send it by email to janicew@darenc.com

Advisory Board or Committee interested in:

1st choice Planning Board, Roanoke Island & Mainland District

2nd choice

3rd choice

Name Colleen R. Shriver

Address 118 Carolina Ct West

City/State/Zip Manteo, NC 27954

Email Address colleen@sunandsea.com

Telephone Home: _____

Business: 252-305-4585

Resident of Dare County: yes no

Occupation: Real Estate Agent

Business Address: CENTURY 21 Nachman Realty

Educational background:

High school graduate. Extended education includes professional education

in the licensing fields of Insurance and Real Estate.

Business and civic experience and skills:

Self employed real estate licensee, 2015 Pres. Outer Banks Association of

REALTORS, Served on or Chaired Association's Legislative Committee 6 yrs

Other Boards/Committees/Commissions on which you presently serve:
Vice-Chair Outer Banks Association of REALTORS Legislative Committee,

Member: Finance & Budget, ByLaws & Policy, RPAC Committees

REFERENCES

List three persons who are not related to you and who have definite knowledge of your qualifications for the position for which you are applying.

Name	Business/Occupation	Address	Telephone
Willo Kelly,	Executive Officer OBAR,	201 Eighth St, Nags Head	252-441-4026
J. Duke Geraghty,	Starco Construction,	103 The Winery, Manteo	252-202-8861
Carl Curnutte,	Dir. Elizabethan Gardens,	1411 Nat'l Park Dr Manteo	2524733234

I understand this application will be kept on the active file for three years and I hereby authorize Dare County to verify all information included in this application.

Date: 1-11-2019

Signature of applicant: 

FOR OFFICE USE ONLY:

Date received: 1-11-19

APPLICATION FOR APPOINTMENT TO DARE COUNTY ADVISORY BOARDS AND COMMITTEES

The Dare County Board of Commissioners believes all citizens should have the opportunity to participate in governmental decisions. One way of participating is by serving as a citizen member on one of the county's advisory boards or committees. If you would like to be considered for appointment to an advisory board or committee, please complete the form below and mail to Rhonda Creef, Dare County Deputy Clerk to the Board, P.O. Box 1000, Manteo, N.C. 27954 or fax it to her at 473-6312.

Advisory Board or Committee interested in:

1st choice Planning Board At Large or District 2

2nd choice Tourism Board

3rd choice _____

Name: John Towler

Address: 1704 Virginia Avenue

City/State/Zip Kill Devil Hills, NC 27948

Telephone Home: (252) 216-9999

Business: (252) 449-5329

Resident of Dare County: yes no

Occupation: police sergeant (Investigations)

Business Address: 102 Town Hall Drive, Kill Devil Hills, NC 27948

Educational background:
1989 Graduated from Cal State University Chico, BA German, 1995 Graduated from Pitt Community College's BLET program,

Business and civic experience and skills:
Member of Domestic Violence Prevention Organization (2005-Present), Member of Child Abuse Task Force (2010-Present), Member of Dare Community Crime Line (2005-Present), YMCA Board of Directors (2011 - Present)

Other Boards/Committees/Commissioners presently serving on:

Board, Committee, or Commission:

none for the Dare County

Expiration Date of Terms: _____

REFERENCES

List three persons who are not related to you and who have definite knowledge of your qualifications for the position for which you are applying.

Name	Business/Occupation	Address	Telephone
Sheila Davies	Mayor, Town of Kill Devil Hills	POB 1605, KDH NC	(252) 475-0033
Donna Trivette	Chair, YMCA Board of Directors,	3000 S. Croatan Hwy, NH	(252) 449-8897
Temple Hegge	Outer Banks Hotline	602 Amanda Street, Manteo	(252) 473-3366

I understand this application will be kept on the active file for five years and I hereby authorize Dare County to verify all information included in this application.

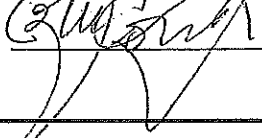
Date: 2/14/2012 Signature of applicant: 
2/2015

FOR OFFICE USE ONLY:

Date received: _____

Date forwarded to County Commissioners: _____

PLANNING BOARD
(Staggered/Three Year Term)

The Planning Board meets to review and recommend action on land use and Development plans and issues for the unincorporated areas of Dare County.

<u>MEMBER</u>	<u>TERM EXPIRATION</u>	<u>ACTION</u>
Jeff Landreth 1135 Burnside Rd. Manteo, NC 27954 473-1569 District 1	2-19	Apptd. 6-16
David Overton 418 Berry Dr. Manteo, NC 27954 473-4802 At Large	2-20	Apptd. 2-08 Reapptd.2-11,14,17
John Finelli, Ch. Box 555 Kitty Hawk, NC 27949 261-8786 At Large	2-21	Apptd. 3-03 Reapptd.2-06,09,12,15, 18
Beth Midgett P.O. Box 250 Hatteras, NC 27943 986-2346 District Four	2-20	Apptd. 8-04 Reapptd.2-06,08,11,14,17
Terry Gore 140 N. Fearing Place Manteo, NC 27954 347-6710 (H),449-0539 (O) At-large	2-19	Apptd. 2-16
Michael Barr 333 Eagle Dr. Kill Devil Hills, NC 27948 480-1499(H), 261-3266(O) District Two	2-20	Apptd. 8-12 Reapptd. 2/14,17
Charles B. Read, Jr. 19 Mallard Cove Loop Southern Shores, NC 27949 255-5055 District 3	2-21	Apptd. 2-15 Reapptd. 2-18

NOTES

MEETING DATE: 2ND Monday of each month
7:30 p.m., DCBC Meeting Room

2/9/96 Attorney Cole referred to the Ordinance Book regarding appointments to the Planning Board. He noted that all appointments should be for three years after an initial staggered term of one, two and three years. The appointments have been for two years. He suggested that in order to comply with the ordinance, that the members whose terms expired in February be given one more year and the rest of the members be given one more year. Approved by the DCBC, unanimous.

All Board members were appointed/reappointed on 2/3/97.

2/02 - Jim Kinghorn appointed to replace J.W. Kierzkowski.

3/03 - John Finelli replaced Jon Britt.

4/03 - Ricky Scarborough, Jr. appointed to fill unexpired term of Mary Aldridge.

8/04 - Beth Midgett filled unexpired term of Jim Kinghorn.

2/05 - Robert Lewis replaced Marcia Parrott.

9/05 - Catherine Morris filled unexpired term of Robert Lewis.

10/07 - Dan Oden, Jr. filled unexpired term of Joseph Thompson.

2/08 - David Overton replaced John G.B. Myers.

2/08 - Henry Haywood replaced Catherine Morris.

8/12 - Michael Barr filled unexpired term of Henry Haywood.

2/15 - Charles B. Read, Jr. replaced Dan Oden, Jr.

2/16 - Terry Gore replaced Elmer Midgett.

2/16 - John Finelli was moved to the At Large seat and apptd. Chairman.

2/16 - Charles Read was moved to the District 3 seat.

6/16 - Jeff Landreth filled unexpired term of Ricky Scarborough, Jr.

REVISED 2/18



Senior Tar Heel Legislature Delegates

Description

See Attached Summary

Board Action Requested

Take Appropriate Action

Item Presenter

Robert Outten, County Manager

February, 2019

BOARD APPOINTMENTS

NC SENIOR TAR HEEL LEGISLATIVE DELEGATE

(Two Year Term)

The following have terms to expire this month:

Kaye White

(Current Term 2/17 – 2/19)

(Originally Apptd. 2/11)

Mary Ellen Hawthorne - Alternate

(Current Term 2/17 – 2/19)

(Originally Apptd. 2/11)

Both would like to be reappointed.

No other applications have been received.

Other Members:

See attached

NC Senior Tar Heel Legislative Delegates
(Two Year Term)

The Senior Tar Heel Legislative Delegates provides information to senior citizens on the legislative process and matters being considered by the NC General Assembly. Must be at least 60 years of age to serve.

<u>MEMBER</u>	<u>TERM EXPIRATION</u>	<u>ACTION</u>
Kaye White 423 W. Villa Dunes Dr. Nags Head, NC 27959 252-441-7062	2/19	Apptd. 2/11 Reapptd 2/13,15,17
Mary Ellen Hawthorne, Alternate 114 St. Clair Rd. Kill Devil Hills, NC 27948 252-480-1062	2/19	Apptd. 2/11 Reapptd 2/13,15,17

NOTES:

- Enacted by Senate Bill 479 (G.S. 143B-181.55)
- Delegates must be 60 yrs. of age or older
- Each county has one delegate and one alternate
- Delegates from all 100 counties serve on committees and meet regularly with the Governor and are a spokesperson for the county they represent. Position requires the ability to keep the County Commissioners informed of Senior Tar Heel Legislative Agenda and to report to other seniors/groups regarding advocacy activities.

2/17



Upcoming Board Appointments

Description

The Dare County Board of Commissioners welcomes citizen participation on its many Boards and Committees.

Following is a list of the Boards and Committees that have terms expiring during the next 3 months. The list indicates when the item will be presented to the County Commissioners and any requirements that may pertain to the appointment.

Instructions on how to obtain and submit an application are attached along with additional information about each of the Boards and Committees with upcoming term appointments.

Board Action Requested

None

Item Presenter

Robert Outten, County Manager

Upcoming Board & Committee Appointments

The Dare County Board of Commissioners welcomes citizen participation on Advisory Boards and Committees. This type of grassroots public involvement is the foundation of democracy and a vital part of maintaining Dare County as a quality place to live.

Following is a list of Boards and Committees that have terms expiring during the next 3 months. The list highlights when the item will be presented to the Board of Commissioners along with any special requirements that may pertain to the appointment.

Information about how to obtain and submit applications follows the list.

March 2019

1. Parks and Recreation Advisory Council

The Advisory Council reviews and advises the Department of Parks and Recreation in its efforts to promote, organize, plan and coordinate activities and programs for youth and adults in Dare County. 1 term expiring

April 2019

1. Airport Authority

The mission of the Dare County Airport Authority is to manage the operation, maintenance and improvement of air services and facilities for the use, convenience, and benefit of the air traveling public. 1 term expiring

2. Manns Harbor Marina Commission

The Manns Harbor Marina Commission is a seven-member group representing recreational, commercial and local interests for the self-governing mutual purpose Manns Harbor Marina. The Commission meets six times per year and reports directly to the Dare County Board of Commissioners. 4 terms expiring

May 2019

1. Veterans Advisory Council

The Veterans Advisory Council helps Dare County Veterans by serving as a liaison with the community in coordinating services and activities benefiting Veterans and their families. Members of the Veterans Advisory Council solicit information and provide updates about community based activities honoring Veterans. 2 terms expiring

2. Zoning Board of Adjustment – Dare County

The Board of Adjustment meets to hear variances and appeals related to land use issues in the unincorporated areas of Dare County. The Chair is appointed by the Board of Commissioners and the Planning Department serves as administrative staff for this Board. 2 terms expiring

-----Instructions for Obtaining and Submitting Applications-----

An application must be submitted in order for your name to be considered for a Board or Committee appointment. The form is available on the Dare County website, or by calling Janice Williams at 475-5800.

COMMISSIONERS' BUSINESS

MANAGER'S / ATTORNEY'S BUSINESS